



Catalogo generale *General catalogue*

Italia, marzo 2014 - Ed. LC008/01
Italy, March 2014 - Ed. LC008/01

L'esperienza suggerisce che è praticamente impossibile pubblicare un catalogo privo di errori; saremo quindi grati ai lettori che vorranno segnalarceli scrivendo al seguente indirizzo di posta elettronica: info@lineacali.it.

Experience has taught us that it is practically impossible to print a catalogue with no errors, we would therefore be grateful to any readers that wish to point any out to us at the following address: info@lineacali.it.

Tutti i diritti sono riservati. È vietata la riproduzione integrale o parziale e la diffusione dei contenuti di questo catalogo (siano essi testi, immagini o disegni) senza la preventiva autorizzazione scritta, da richiedere al seguente indirizzo di posta elettronica: info@lineacali.it.

All rights reserved. It is forbidden to reproduce, in part or in whole, and to circulate the contents of this catalogue (text, images and drawings) without prior written authorization, to be requested at the following email address: info@lineacali.it.

Le caratteristiche tecniche sono passibili di modifiche.

The technical characteristics are subject to modification.

Il formato elettronico (PDF) di questo catalogo è disponibile all'interno del sito www.lineacali.it.

The electronic format (PDF) of this catalogue is available on the web site www.lineacali.it

CREDITI

Studio creativo Fantàsia
"Dove le idee sputano come funghi."
www.studiofantasia.it

CREDITS

*Fantàsia creative studio
"Where ideas sprout like mushrooms."
www.studiofantasia.it*

Direzione artistica: Zack!
Testi: Alberto Bondoni
Traduzioni: Aideen Connolly
Informazioni tecniche: Vanessa Martinelli
Stampa: Intese Grafiche

*Art direction: Zack!
Text: Alberto Bondoni
Translations: Aideen Connolly
Technical information: Vanessa Martinelli
Print: Intese Grafiche*

indice / *index*

INDICE COLLEZIONI <i>INDEX BY COLLECTION</i>	4	MANIGLIONI <i>PULL HANDLES</i>	190	COPRICERNIERE <i>HING COVERS</i>	214
AZIENDA <i>FACTORY</i>	9	POMOLI PER PORTE <i>DOOR KNOBS</i>	201	CATENACCI E CAMPANELLI <i>DEADBOLTS AND BELLS</i>	215
LEGENDA <i>LEGEND</i>	16	BATTENTI <i>DOOR KNOCKERS</i>	204	CREMONESI MP ASTE ESTERNE <i>WINDOW HANDLES GRATZ MP</i>	216
FINITURE <i>FINISHINGS</i>	17	ROSETTA RIBASSATA <i>REDUCED ROSE</i>	207	APPENDIABITI <i>COAT HOOKS</i>	217
COLLEZIONE DESIGN <i>DESIGN COLLECTION</i>	18	BOCCHETTE <i>ESCUTCHEONS</i>	208	MANIGLIE E ACCESSORI PER PORTE BLINDATE <i>HANDLES AND ACCESSORIES FOR ARMORED DOORS</i>	218
COLLEZIONE CLASSIC <i>CLASSIC COLLECTION</i>	94	BOCCHETTE SET WC <i>WC ESCUTCHEONS SET</i>	210	PLACCHE INCASSO <i>INSET HANDLE KIT</i>	222
COLLEZIONE BASIC <i>BASIC COLLECTION</i>	164	CHIAVI <i>KEYS</i>	212	POMOLI PER MOBILI <i>CABINET KNOBS</i>	226
		FERMAPORTE <i>DOOR STOP</i>	213	MATERIALE PUBBLICITARIO <i>ADVERTISING MATERIAL</i>	228
				ISTRUZIONI DI MONTAGGIO <i>MOUNTING INSTRUCTIONS</i>	232

collezioni / collections

DESIGN



20 Aqua



23 Ala



26 Brera



29 Duna



32 Elios



35 Elle



38 Elle pelle



41 Fish



44 Ibis



47 Jet



50 Moma



53 Open

collezioni / *collections*

DESIGN



57 Prisma



60 Profilo



63 Riflesso



65 Rombo



68 Sintesi



70 Sintesi Mart



73 Sintesi Wengé



75 Slim



78 Slim pelle



81 Star



83 Thais



86 Trendy



88 Zen



91 Zen wengé

collezioni / collections

CLASSIC



96 Aldar



99 Dafne



102 Dalia

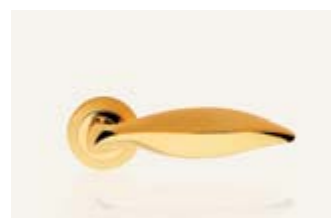

105 Delfino



108 Elika



111 Erica



114 Flavia



117 Havana



120 Karina



123 Kuba



126 Kuba pomolo



128 Lady

collezioni / *collections*

CLASSIC



131 Libera



134 Marina



137 Nota



140 Pin-up



143 Relax



146 Rose



150 Sirena



153 Tess



156 Tosca



160 Vola

collezioni / *collections*

BASIC



166 Brixia



169 Garda



172 Ibiza



175 Mare



178 Onda



181 Piuma



184 Saba

azienda / *factory*

Apriamo le porte con stile
We open doors in style



La differenza tra una maniglia ed un semplice pezzo di ottone nasce nel 1986, quando lanciammo i nostri prodotti seguendo l'idea della funzionalità abbinata al design.

Perché il design senz'anima lo abbiamo provato tutti ed è scomodo, tanto quanto la brutta funzionalità.

Abbiamo quindi scelto di realizzare quelle maniglie che noi stessi metteremmo a casa nostra, maniglie che resistano a tutto: usura, urti, tempo, grazie ad innovative tecniche di fissaggio e di protezione, come la finitura PVD Zirconium Protection.

Al contempo, le abbiamo volute belle, molto belle, come ogni vero accessorio che si rispetti.

E alla fine, visto che volevamo il meglio, ci siamo impegnati a far sì che ogni maniglia venisse concepita e realizzata esclusivamente in Italia, rispettando pienamente i requisiti di legge previsti dalle normative europee.

A questo punto, provate ad immaginare la maniglia perfetta per la vostra abitazione o per il vostro ufficio: probabilmente la troverete qui.

The difference between a handle and a simple piece of brass arose in 1986, when we launched our products that combined both functionality and design.

We've all tried design without a soul and its awkward, just like brute functionality.

We therefore chose to create handles that we ourselves would choose for our own house, handles that resist everything: wear, blows, time, thanks to innovative fixing and protection techniques such as the Zirconium Protection finish - PVD.

At the same time, we wanted our handles to be attractive, like all accessories should be.

And finally, because we wanted the best, we committed ourselves to ensuring that every handle was designed and created exclusively in Italy, in full compliance with the legislative requirements of European standards.

And now, try and image the ideal handle for your house or office: the chances are you'll find it here.



azienda / *factory*

Nel futuro probabilmente le porte
si apriranno con il pensiero...

fino ad allora, però, sogneranno
sempre una maniglia Linea Calì.





Produciamo maniglie di alta qualità, e lo facciamo solo in Italia.



Siamo orgogliosi di garantire ai clienti la produzione italiana di tutti i nostri prodotti nel rispetto delle più recenti normative Europee in tema di qualità delle materie prime utilizzate, caratteristiche tecniche e resistenza dei trattamenti protettivi delle superfici (rif. UNI EN ISO 9227).

A riprova di ciò su ogni articolo che commercializziamo stampiamo un marchio di riconoscimento che ne attesta l'autenticità, garantendo così al cliente l'acquisto di una maniglia di alta qualità interamente prodotta in Italia.

Garantiamo inoltre 10 anni i prodotti con finiture cromo lucido o cromo satinato, e 20 anni se trattati con il trattamento Zirconium Protection (PVD), adatto dove è richiesta una resistenza particolare a causa di difficili situazioni climatiche come salsedine, alta umidità o situazioni di impiego usuranti.

We are proud that we can guarantee our customers products that are manufactured entirely in Italy, in compliance with the most recent European standards on the quality of the raw materials used, the technical characteristics and the resistance of surface treatments (ref. UNI EN ISO 9227).

As evidence thereof, we mark each and every item that we sell, certifying its authenticity, thus guaranteeing the customer a high quality handle produced entirely in Italy.

Furthermore, all our products with a polished chrome or satin chrome finish are covered by a 10 year guarantee and by a 20 year guarantee if treated with a physical vapour deposition (PVD) using Zirconium Protection, a coating that is ideal whenever a particularly high resistance is required due to difficult climatic situations such as high salt content or humidity in the air or situations of high wear and tear.



azienda / factory

Amiamo il "verde" che ci circonda, e lo rispettiamo in ogni processo produttivo.

Siamo estremamente rispettosi dell'ambiente che circonda la nostra azienda, la nostra vita, perciò adottiamo un comportamento eco-responsabile per ridurre gli sprechi e migliorare la qualità della vita sul posto di lavoro.

We respect the environment that surrounds our company, our life. We therefore adopt an environmentally responsible behaviour to reduce wastage and improve the quality of life in the workplace.

Tutti i principali processi produttivi vengono svolti in un'ottica eco-sostenibile, inoltre pretendiamo che i nostri fornitori adottino un Sistema di Gestione Ambientale per prevenire l'inquinamento, purificando le emissioni in atmosfera e depurando le acque reflue.

All the principle production processes are performed with a view to sustainability and we also require that our suppliers adopt an Environmental Management System to prevent pollution, purifying atmospheric emissions and waste water.

Un grosso impegno, che ci sentiamo di portare avanti sempre con più convinzione perché ci crediamo fermamente.

A major commitment but one that we are pleased to pursue with increasing conviction as we so firmly believe in it.





Grazie alla nostra esperienza pluriennale nel mondo del lusso, abbiamo intuito la necessità da parte dei nostri clienti di possedere collezioni sempre più particolari ed esclusive.

Più di 20 anni fa abbiamo così iniziato a trasformare oggetti di uso comune in gioielli dalle mille sfaccettature impreziosendoli con cristalli SWAROVSKI ELEMENTS originali.

Cometa, Cosmic, Crystal, Diamante, Erika Crystal, Elios Crystal, Fish Crystal, Gemma, Havana Mesh, Idea, Luce, Opera Crystal, Profilo Mesh, Reflex, Riflesso Black, Riflesso Mesh, Riflesso Rocks, Shell Mesh, Sintesi Mesh, Tiffany Mesh, Veronica, Viola e Zen Mesh sono i nomi di tutte le collezioni di pregio dagli infiniti riflessi di luce MADE WITH SWAROVSKI ELEMENTS.

Thanks to our years of experience in the world of luxury, we understand our customers' need to possess collections that are more and more special and exclusive.

So over 20 years ago we started transforming everyday objects into multi faceted jewels with original SWAROVSKI ELEMENTS.

Cometa, Cosmic, Crystal, Diamante, Erika Crystal, Elios Crystal, Fish Crystal, Gemma, Havana Mesh, Idea, Luce, Opera Crystal, Profilo Mesh, Reflex, Riflesso Black, Riflesso Mesh, Riflesso Rocks, Shell Mesh, Sintesi Mesh, Tiffany Mesh, Veronica, Viola and Zen Mesh are the collections with a infinite reflections of light MADE WITH SWAROVSKI ELEMENTS crystals.



azienda / *factory*

Produciamo maniglie di lusso
impreziosite dagli inimitabili cristalli
SWAROVSKI ELEMENTS.



legenda / legend



Novità
New



Design brevettato - diritto di esclusiva sulla produzione e commercializzazione
Patented design - exclusive right on manufacturing and marketing



Slim - rosetta bassa h. 6 mm
Slim - reduced rose h. 6 mm

finiture / *finishings*

AN	ottone invecchiato <i>aged brass</i>	CS	cromo satinato <i>satin chrome</i>	OL	ottone lucido verniciato <i>polished brass</i>
BM	bronzo opaco <i>matt bronze</i>	FV	ferro effetto invecchiato <i>aged iron (brass)</i>	OM	oro + oro sabbato <i>polished gold + matt gold mix</i>
BO	bronzo sfumato opaco <i>bronze</i>	MC	cromo + cromo sabbato <i>chrome + matt chrome mix</i>	OS	ottone satinato <i>satin brass</i>
CC	cromo satinato + cromo <i>satin chrome + polished chrome mix</i>	MO	oro + oro sabbato. <i>polished gold + matt gold mix.</i>	OT	ottone satinato + ottone lucido <i>satin brass + polished brass mix</i>
CE	nero opaco + cromo <i>matt black + polished chrome mix</i>	NS	nickel satinato <i>satin nickel</i>	OV	ottone bronzato verniciato <i>bronzed brass</i>
CM	cromo + cromo sabbato. <i>chrome + matt chrome mix.</i>	OB	ottone bronzato satinato <i>bronzed brass + satin brass mix</i>	OZ	oro zecchino <i>gold plated</i>
CN	nickel satinato + cromo <i>satin nickel + polished chrome mix</i>	OC	cromo + ottone lucido <i>chrome + polished brass mix</i>	PM	patiné <i>patiné mat</i>
CP	cromo perla <i>pearl chrome</i>	OF	oro francese <i>french gold</i>	PV	titanio <i>titanium</i>
CR	cromo lucido <i>polished chrome</i>	OG	ottone bronzato graffiato <i>bronzed brass</i>	VE	nero opaco <i>matt black</i>

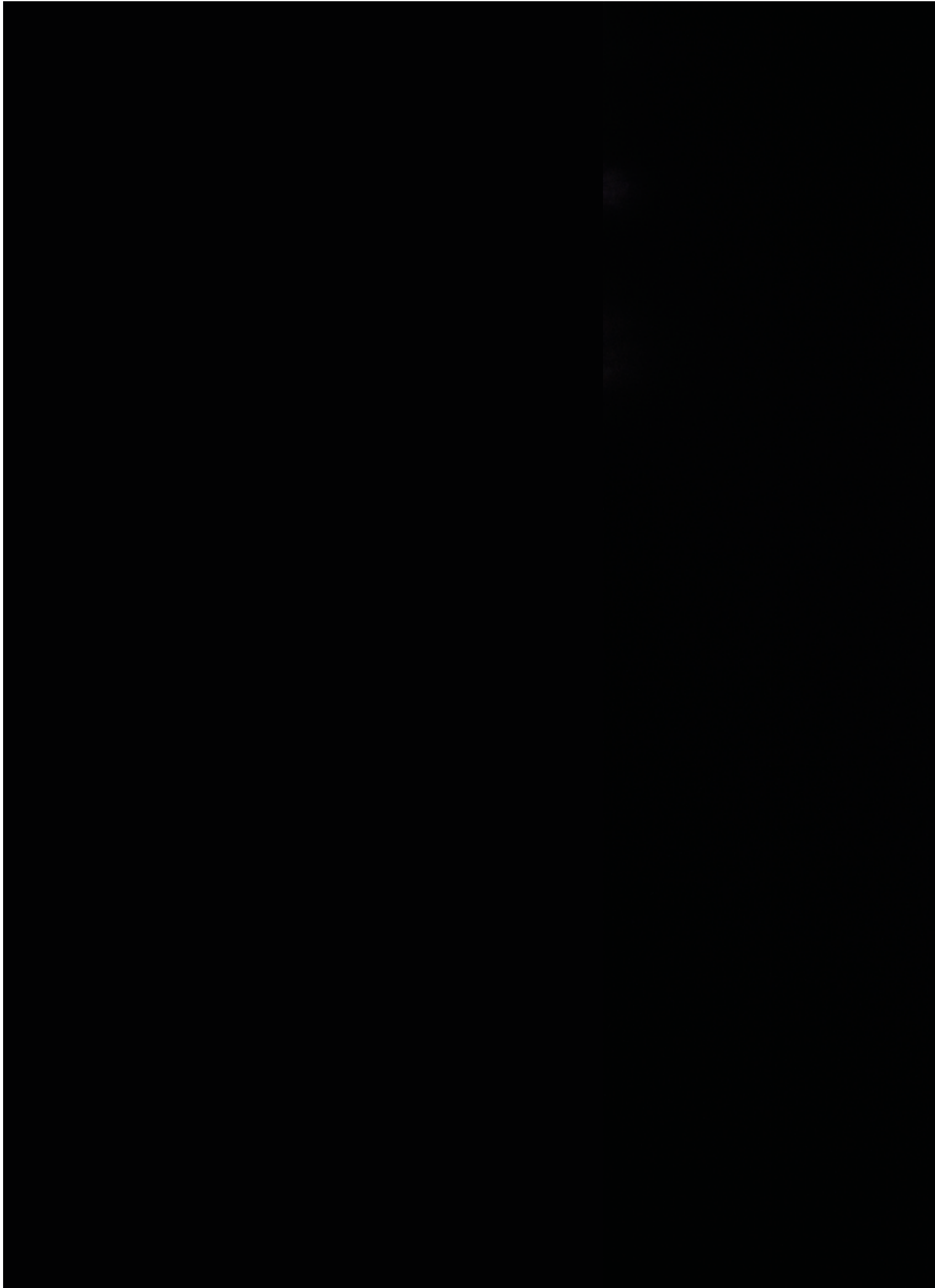

Design



Aqua

COLLEZIONE 2014
2014 COLLECTION

design by
Dmitry Kozinenko

I motivi che la risacca del mare disegna sulla battigia caratterizzano l'inusuale forma di questa collezione dal design particolarmente moderno e innovativo.

The patterns that the sea's tide leave on the water's edge characterise the unusual form of this collection with a particularly modern and innovative design.

ONLY MADE IN ITALY





BM bronzo opaco
matt bronze



CR cromo lucido
polished chrome



CS cromo satinato
satin chrome



OZ oro zecchino
gold plated



COD. 1440 RB 024

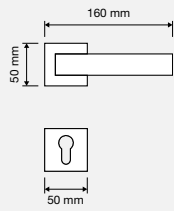

COD. 1440 RB 019

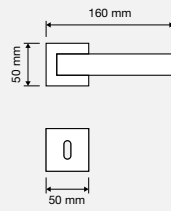

COD. 1440 PL

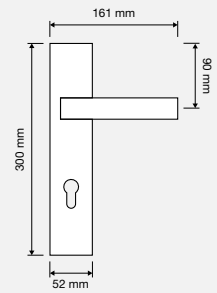

COD. 1440 DK

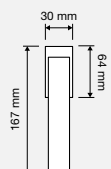

La mano scivola sul dorso della maniglia come il vento sulle ali di un aeroplano, ma il design consapevole dona una presa estremamente solida, confortevole e sicura.

Your hand glides over the handle like the wind on the wings of an airplane, but the conscious design results in an extremely solid, comfortable and secure grip.

ONLY MADE IN ITALY

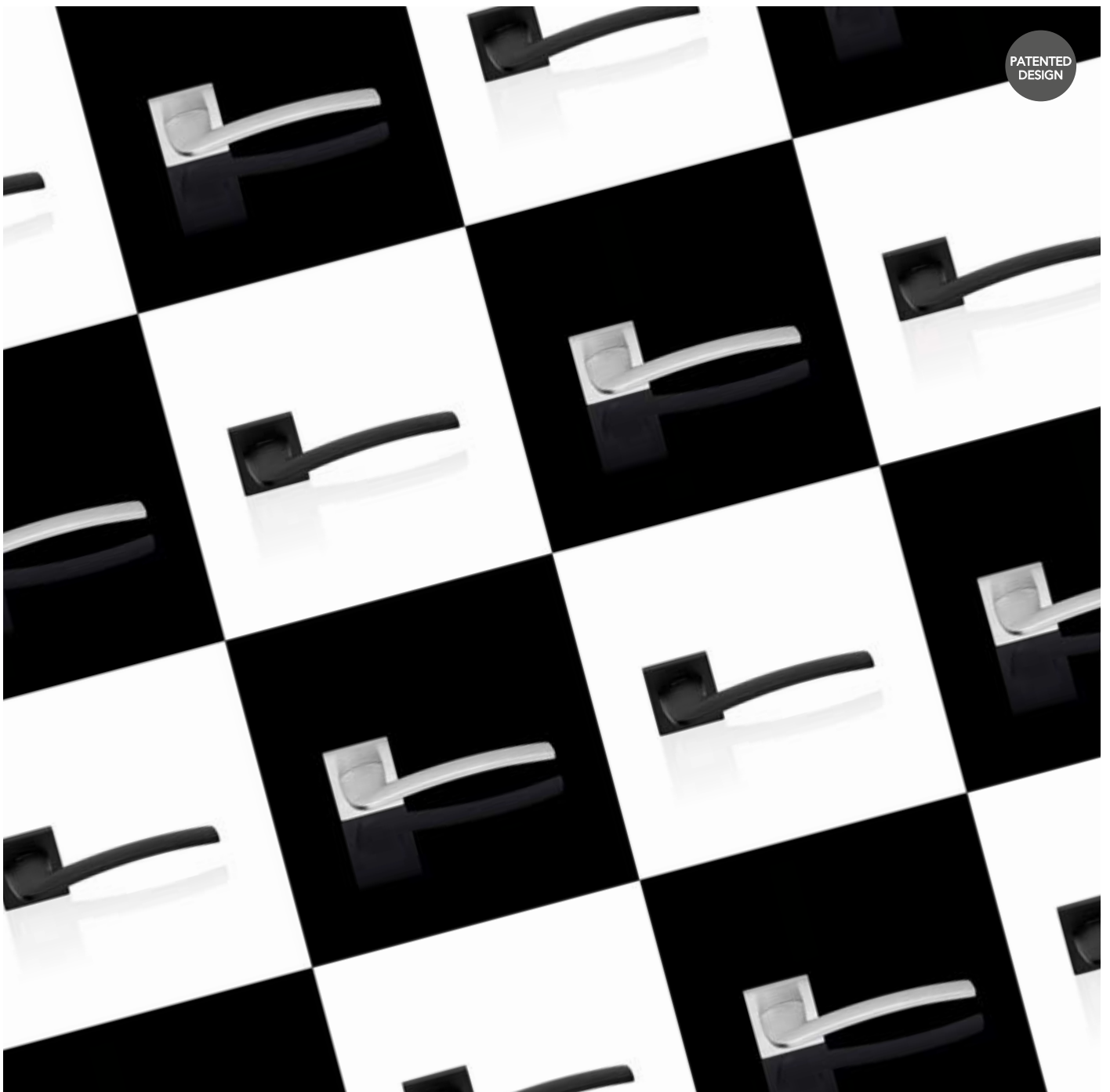



ALA | FINITURE / FINISHINGS



CR cromo lucido
polished chrome



CS cromo satinato
satin chrome



OL ottone lucido verniciato
polished brass



VE nero opaco
matt black



COD. 1385 RB 019

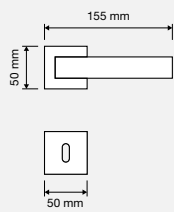

COD. 1385 PL

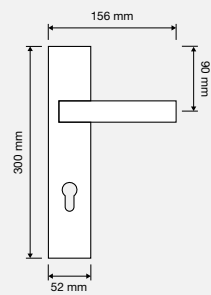

COD. 1385 DK

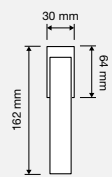

Brera

COLLEZIONE 2008
2008 COLLECTION

Ispirata alle più grandi opere di Mondrian, Kandinsky e Pollock, la collezione Brera eleva la forma, le linee e i colori grazie al concetto di astrazione, dichiarando la propria "fisicità" solo in alcune sue caratteristiche.

Inspired by the greatest works of Mondrian, Kandinsky and Pollock, the Brera collection elevates form, lines and colours thanks to the concept of abstraction, declaring its "physical" nature in just a few of its characteristics.

ONLY MADE IN ITALY

PATENTED
DESIGN





CR cromo lucido
polished chrome



CS cromo satinato
satin chrome



OZ oro zecchino
gold plated

BRERA | FANTASIE / FANTASY



1170



1171



1172



1173



1174



1175



1176



1177



1178



1179



1180



1181



COD. 1173 RB 019

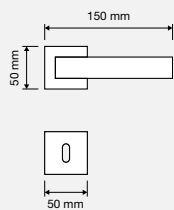

COD. 1173 PL

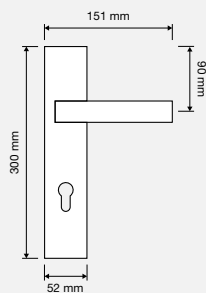

COD. 1173 DK

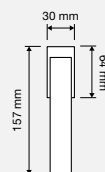

COD. 1173 PI

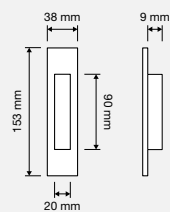

COD. 1173 PT

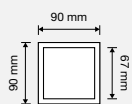

COLLEZIONE 2013
2013 COLLECTION

design by
Dmitry Kozinenko

Duna

Plasmata dalla forza del vento, esprime la sensazione di mistero e maestosità del deserto.

Shaped by the force of the wind, it conveys the sensation of mystery and majesty of the desert.

ONLY MADE IN ITALY





DUNA | FINITURE / FINISHINGS



BM bronzo opaco
matt bronze



CR cromo lucido
polished chrome



CS cromo satinato
satin chrome



OZ oro zecchino
gold plated



COD. 1410 RB 019

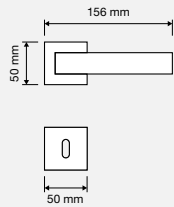

COD. 1410 RB 023

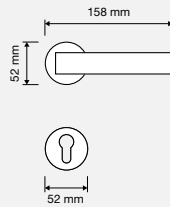

COD. 1410 PL

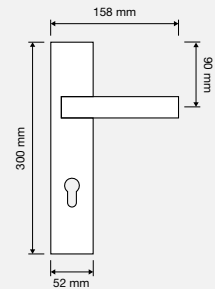

COD. 1410 DK

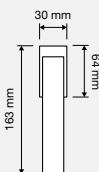

Elios

COLLEZIONE 2011
2011 COLLECTION

Forme aggraziate insospettabilmente decise danno vita a un design estremamente formale e rigoroso.

Graceful forms yet unexpectedly decisive give life to an extremely formal and rigorous design.

ONLY MADE IN ITALY

PATENTED
DESIGN





ELIOS | FINITURE / FINISHINGS



CM cromo + cromo sabbato.
chrome + matt chrome mix.



CR cromo lucido
polished chrome



CS cromo satinato
satin chrome



MO oro + oro sabbato.
polished gold + matt gold mix.



OZ oro zecchino
gold plated



ELIOS | MODELLI / MODELS



COD. 1341 RB 019

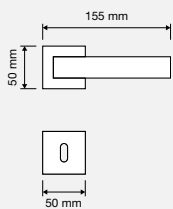

COD. 1341 PL

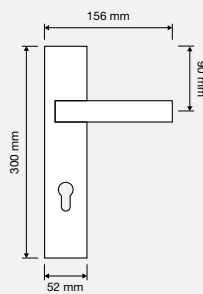

COD. 1341 DK

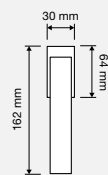

L'unione di più elementi differenti fra loro, tondi e quadri, dà vita a una collezione sofisticata e semplice al tempo stesso.

The combination of several different elements, round and square, gives life to a sophisticated but at the same time simple collection.

ONLY MADE IN ITALY

PATENTED
DESIGN





ELLE | FINITURE / FINISHINGS



CC cromo satinato + cromo
satin chrome + polished chrome mix



CR cromo lucido
polished chrome



CS cromo satinato
satin chrome

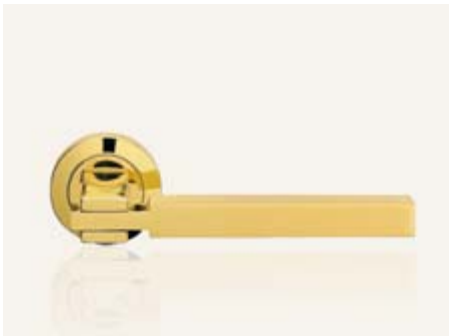

OL ottone lucido verniciato
polished brass



OT ottone satinato + ottone lucido
satin brass + polished brass mix



OZ oro zecchino
gold plated

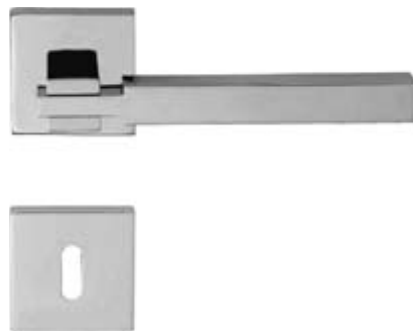

COD. 1050 RB 102

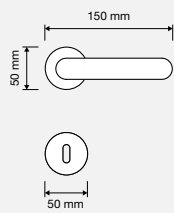

COD. 1050 RB 019

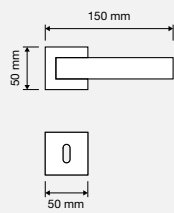

COD. 1050 MZ 240*

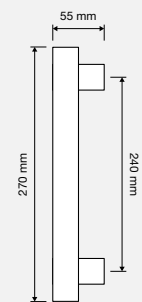

COD. 1050 MN 240*

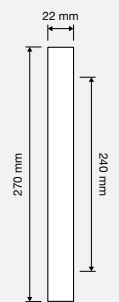

* Interassi disponibili / available distances
240 - 320 - 440 - 500 - 800



COD. 1050 DK

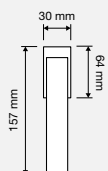

COD. 1050 CH



Elle pelle

COLLEZIONE 2005
2005 COLLECTION

La tradizione italiana della lavorazione artistica del pellame dona una presa estremamente piacevole, morbida e lussuosa, a una collezione che si distingue per il design sofisticato e semplice al tempo stesso.

The Italian tradition of the artistic working of leather gives an extremely pleasant, soft and luxurious grasp to a collection that stands out for its sophisticated yet simple design.

ONLY MADE IN ITALY





CR cromo lucido
polished chrome



CS cromo satinato
satin chrome



OL ottone lucido verniciato
polished brass



OZ oro zecchino
gold plated



1052 pelle nera
black leather



1051 pelle marrone
brown leather



COD. 1052 RB 102

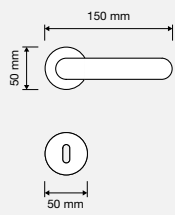

COD. 1052 PL

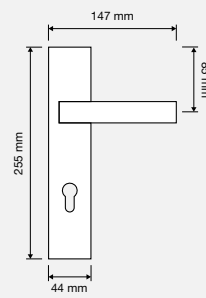

COD. 1052 MZ 240

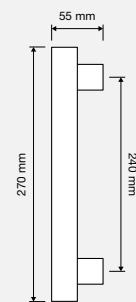

COD. 1052 MN 240

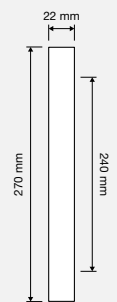

COD. 1052 DK

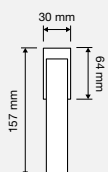

COLLEZIONE 2013
2013 COLLECTION

design by
Dmitry Kozinenko

Fish

Morbidezza e fluidità in una linea affusolata,
con un richiamo esplicito all'ambiente marino.

*Softness and fluidity in a streamlined design with
an explicit reference to marine environments.*

ONLY MADE IN ITALY





FISH | FINITURE / FINISHINGS



BM bronzo opaco
matt bronze



CR cromo lucido
polished chrome



CS cromo satinato
satin chrome



MC cromo + cromo sabbiato
chrome + matt chrome mix



OM oro + oro sabbiato
polished gold + matt gold mix



OZ oro zecchino
gold plated



COD. 692 RB 023

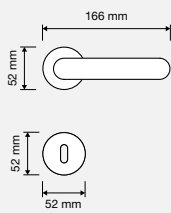

COD. 692 PL

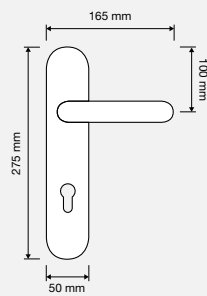

COD. 692 DK

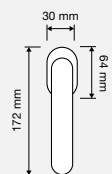

Ibis

COLLEZIONE 2013
2013 COLLECTION

design by
Yurij Cegla

Linee sinuose si rincorrono dando vita a una forma naturale che, idealmente, ricorda un ramo sulla quale si è appoggiato l'Ibis, uccello americano dal piumaggio rosso come il tramonto.

Sinuous lines follow each other giving life to a natural form that ideally resembles a branch on which an ibis is perched, an American bird with scarlet feathers like a sunset.

ONLY MADE IN ITALY

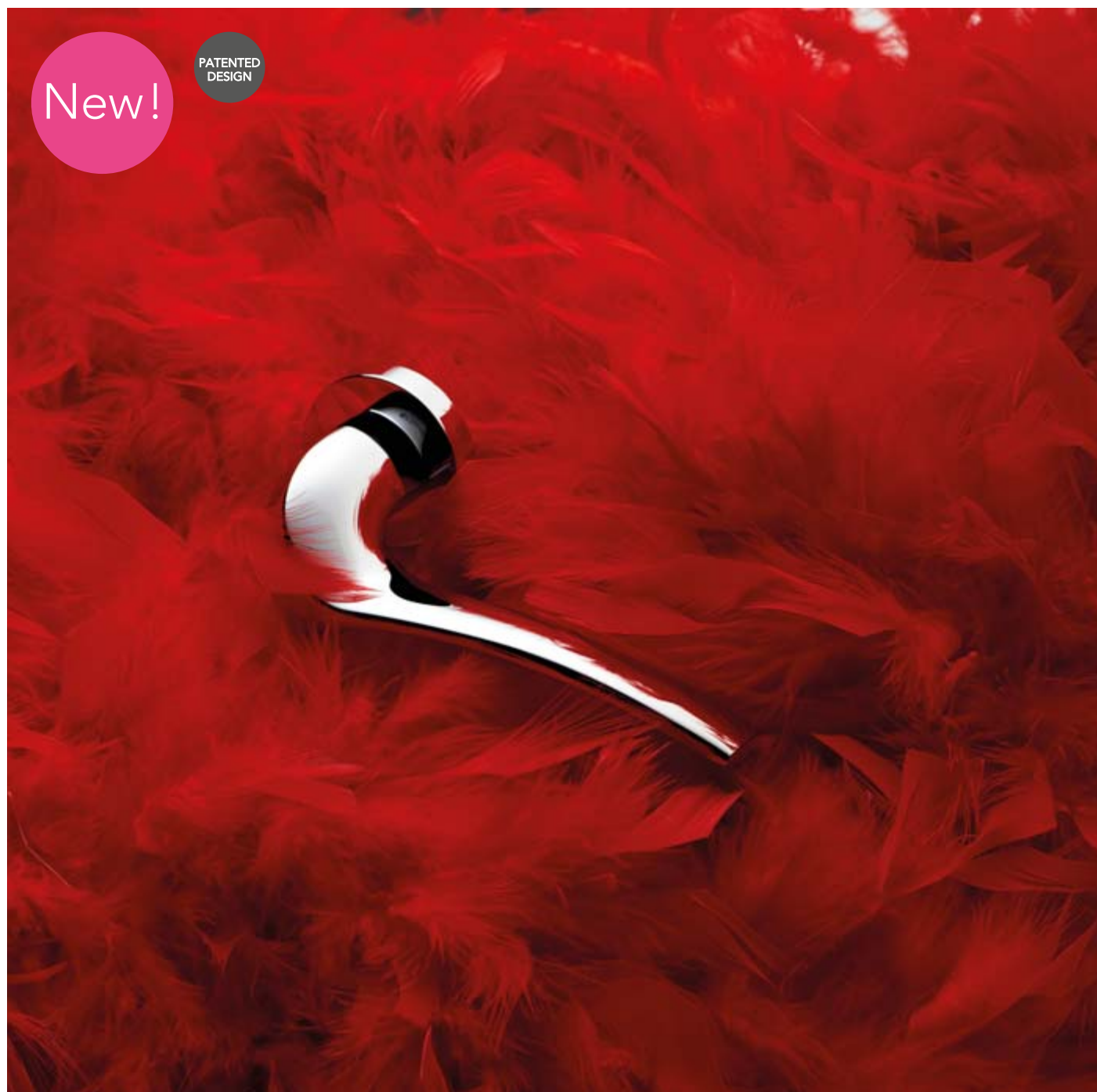



CR cromo lucido
polished chrome



CS cromo satinato
satin chrome



OL ottone lucido verniciato
polished brass



OZ oro zecchino
gold plated



PM patiné
patiné mat



VE nero opaco
matt black



IBIS | MODELLI / MODELS



COD. 691 RB 023

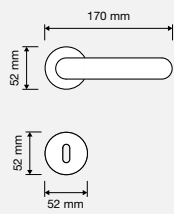

COD. 691 DK

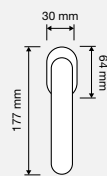

COD. 691 MN 300

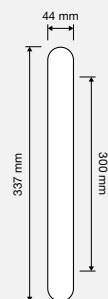

Linee taglienti, ma confortevoli, talmente perfette e armoniche da non dover aggiungere altro.

Sharp lines, but comfortable, so perfect and harmonious that anything else would be redundant.

ONLY MADE IN ITALY

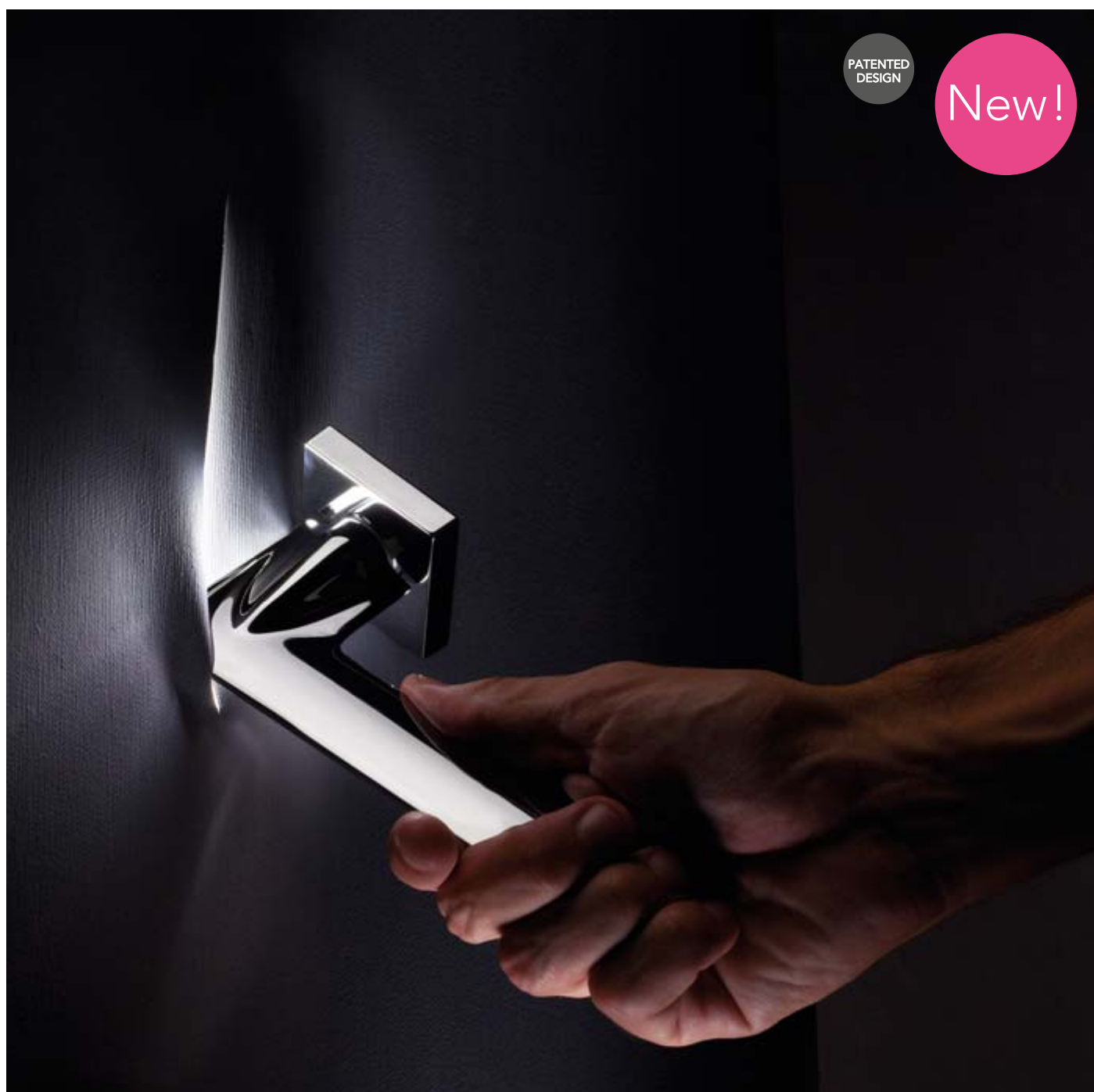

PATENTED
DESIGN

New!



JET | FINITURE / FINISHINGS



CR cromo lucido
polished chrome

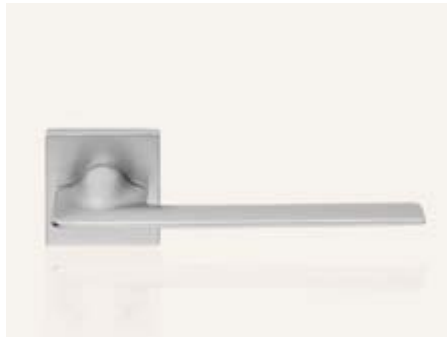

CS cromo satinato
satin chrome



OZ oro zecchino
gold plated



VE nero opaco
matt black

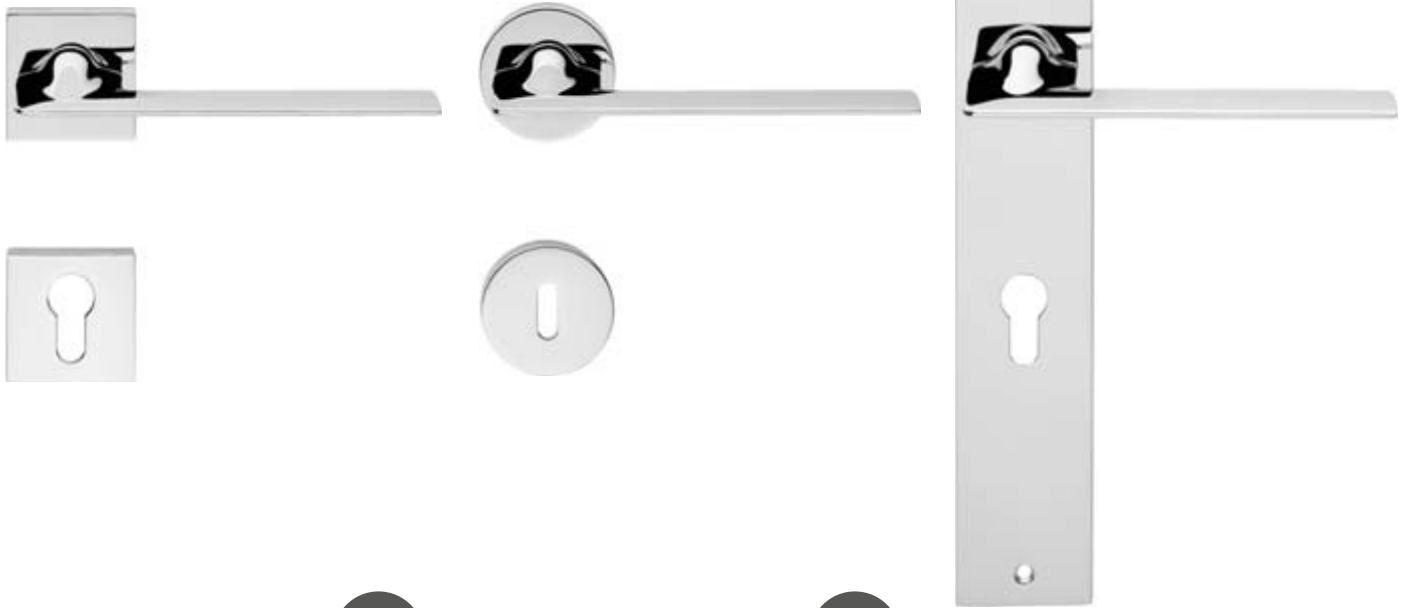

COD. 1425 RB 019

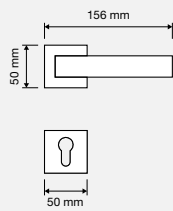

COD. 1425 RB 023

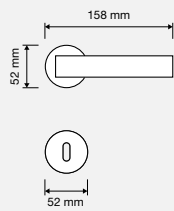

COD. 1425 PL

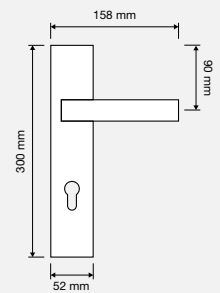

COD. 1425 DK

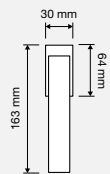

I mosaici più famosi di Riccardo Licata riaffiorano alla mente grazie a particolarissime fantasie realizzate in vetro artigianale.

The most famous mosaics of Riccardo Licata come to mind thanks to the very unusual patterns created using handcrafted glass

ONLY MADE IN ITALY

PATENTED
DESIGN





CR cromo lucido
polished chrome



CS cromo satinato
satin chrome



OZ oro zecchino
gold plated

MOMA | FANTASIE / FANTASY



1190



1191



1192



1193



1194



1195



1196



1197



1198



1199

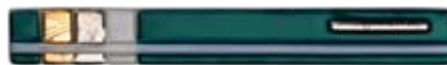

1200



1201



MOMA | MODELLI / MODELS



COD. 1193 RB 102

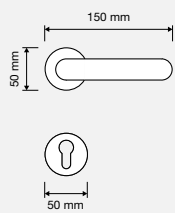

COD. 1193 CR

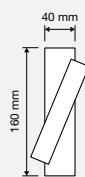

COD. 1193 MN 240

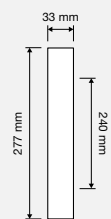

Un'interessante parentesi [quadra] di stile in grado di valorizzare ogni porta con un tocco di originalità.

An interesting digression of style [square bracket] capable of adding value to all doors with a touch of originality.

ONLY MADE IN ITALY

PATENTED
DESIGN





OPEN | FINITURE / FINISHINGS



CR cromo lucido
polished chrome



CS cromo satinato
satin chrome

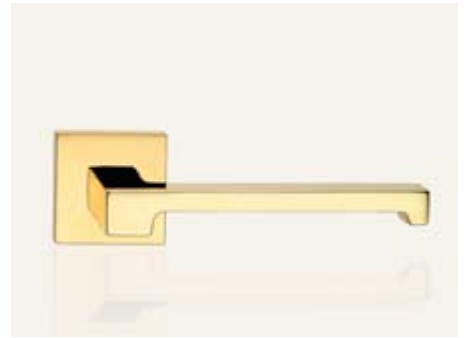

OL ottone lucido verniciato
polished brass



OZ oro zecchino
gold plated



COD. 1105 RB 019

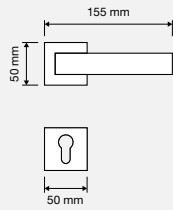

COD. 1104 PL

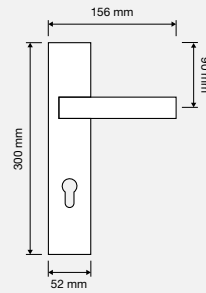

COD. 1104 SL

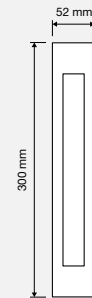

COD. 1105 PT



COD. 1105 PG

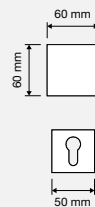

COD. 1105 DK

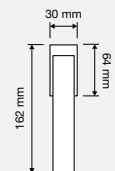



COD. 1105 MN 207

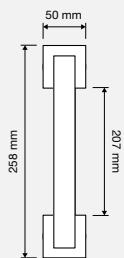

COD. 1104 ED/ES

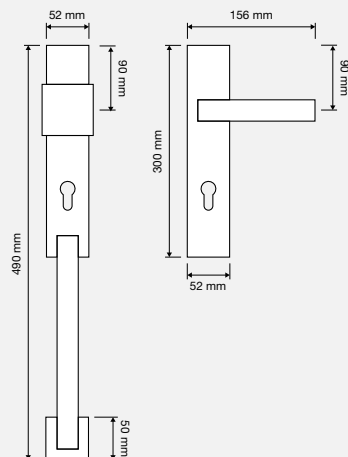

Prisma

Il design particolarmente eclettico e inconsueto, caratterizzato da un'impugnatura di forma romboidale, ne fa il complemento d'arredo ideale per gli ambienti più moderni.

The particularly eclectic and unusual design, characterized by the rhomboid shaped hand-grip, make it the ideal furnishing accessory for the most modern environments.

ONLY MADE IN ITALY





PRISMA | FINITURE / FINISHINGS



CR cromo lucido
polished chrome



CS cromo satinato
satin chrome



MC cromo + cromo sabbato
chrome + matt chrome mix



OL ottone lucido verniciato
polished brass



OM oro + oro sabbato
polished gold + matt gold mix



COD. 1280 RB 019

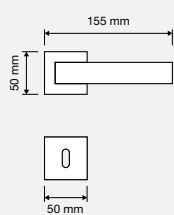

COD. 1281 PL

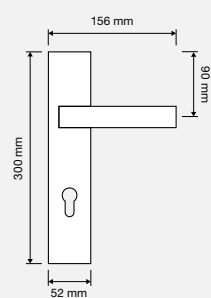

COD. 1280 DK

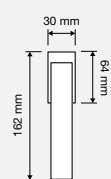

Profilo

COLLEZIONE 2004
2004 COLLECTION

Uno dei best-sellers di Linea Cali, celebre per via del suo design classico ma che strizza l'occhio a quello più contemporaneo, che riveste il ruolo di perfetto complemento d'arredo.

One of the best sellers of Linea Cali, made famous by its classical design but which winks at the most contemporary of designs, playing the role of perfect furnishing accessory.

ONLY MADE IN ITALY

PATENTED
DESIGN





CR cromo lucido
polished chrome



CS cromo satinato
satin chrome



MC cromo + cromo sabbato
chrome + matt chrome mix



OL ottone lucido verniciato
polished brass



OM oro + oro sabbato
polished gold + matt gold mix



COD. 1040 DK

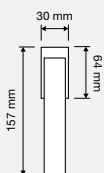

COD. 1040 CR

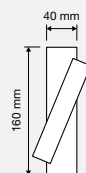

COD. 1042 PI

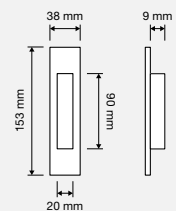



COD. 1040 RB 102

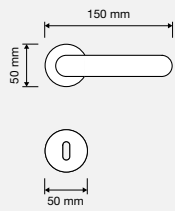

COD. 1040 PL

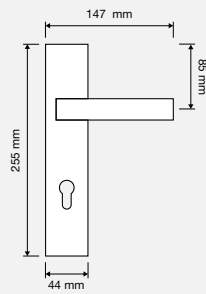

COD. 1040 MN 240



COD. 1040 RB 019

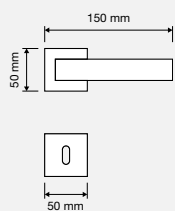

COLLEZIONE 2012
2012 COLLECTION

Riflesso

Una collezione che vuole essere protagonista, caratterizzata da un'impugnatura importante capace di riflettere l'ambiente circostante.

A collection that aims for the leading role, characterised by an imposing handgrip that is capable of reflecting its surroundings.

ONLY MADE IN ITALY

PATENTED
DESIGN

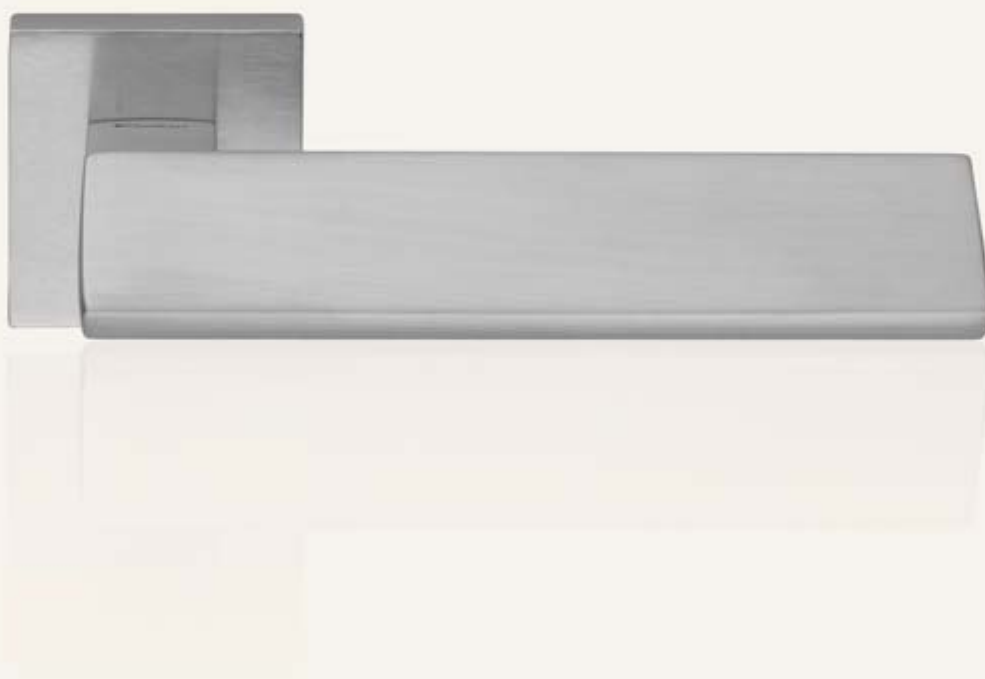



CR cromo lucido
polished chrome



CS cromo satinato
satin chrome



VE nero opaco
matt black



COD. 1360 RB 019

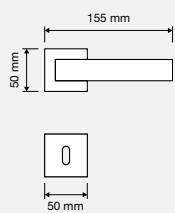

COD. 1360 PL

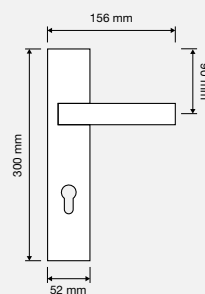

COD. 1360 DK

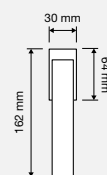

COLLEZIONE 2013
2013 COLLECTION

design by
Dmitry Kozinenko

Rombo

Un design eclettico che non scende a compromessi dedicato a chi è coraggioso e determinato nello stile.

An eclectic design without compromise dedicated to those looking for a daring and determined style.

ONLY MADE IN ITALY

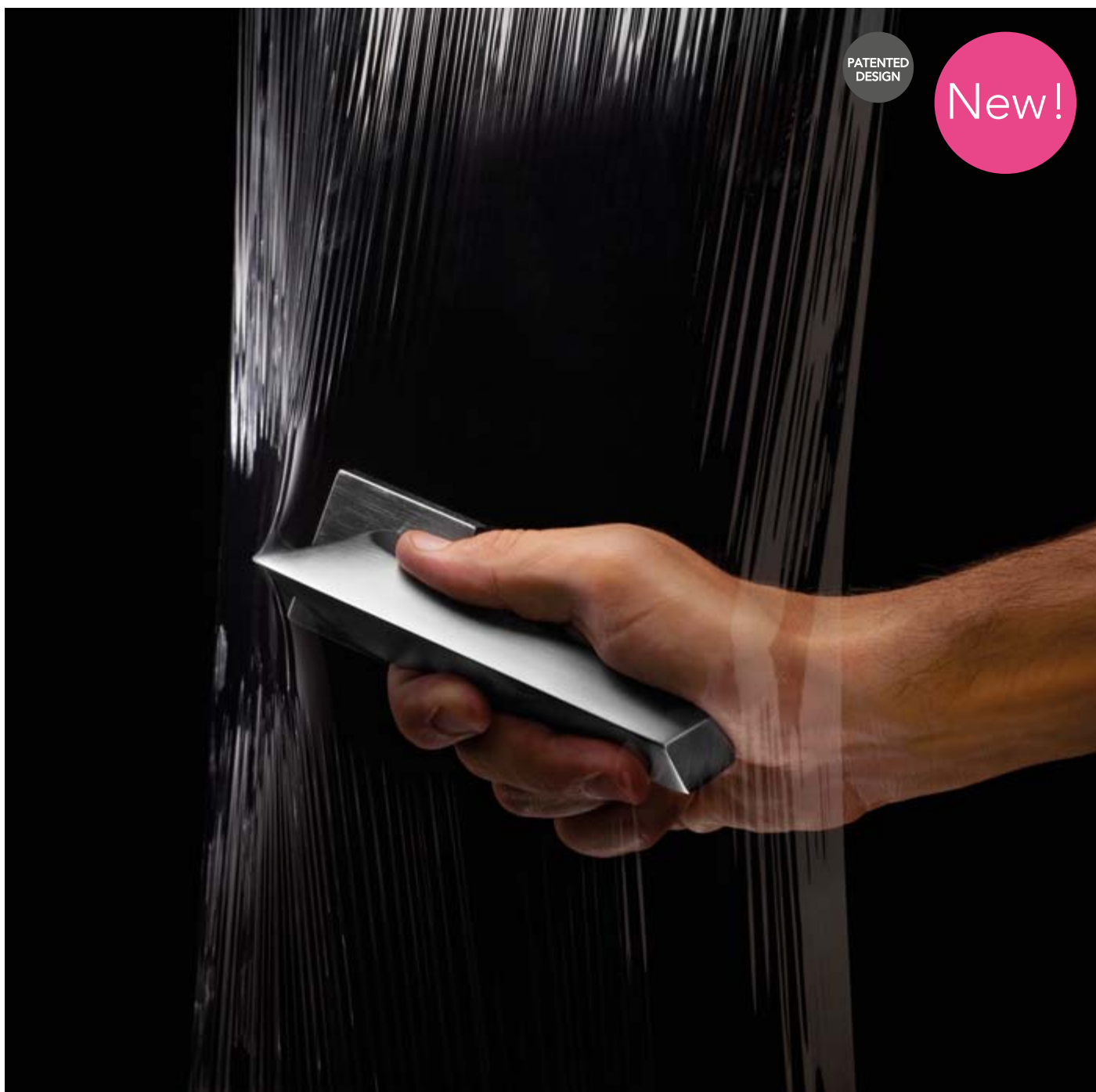



ROMBO | FINITURE / FINISHINGS

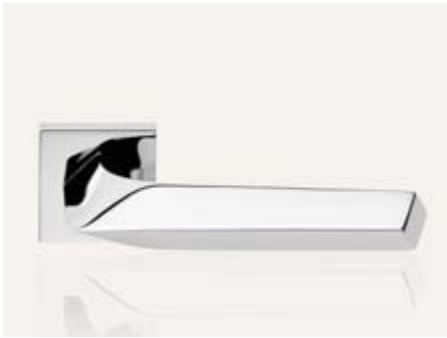

CR cromo lucido
polished chrome



CS cromo satinato
satin chrome



OZ oro zecchino
gold plated



COD. 1420 RB 019

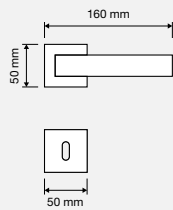

COD. 1420 PL

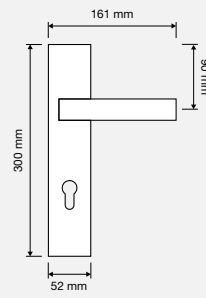

COD. 1421 PL

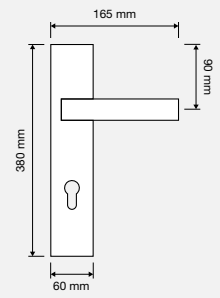

COD. 1420 DK

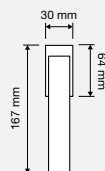

Sintesi

COLLEZIONE 2010
2010 COLLECTION

Linee decise, lineari ed estremamente rigorose, ne fanno un complemento d'arredo perfetto per tutti quegli ambienti dove il design regna sovrano.

Decisive, linear and extremely meticulous lines, make it the perfect furnishing accessory for all surroundings where design reigns supreme.

ONLY MADE IN ITALY

PATENTED
DESIGN





CR cromo lucido
polished chrome



CS cromo satinato
satin chrome



OL ottone lucido verniciato
polished brass



PV titanio
titanium



COD. 1300 RB 019

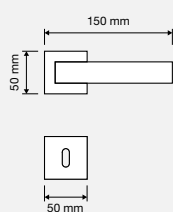

COD. 1300 DK

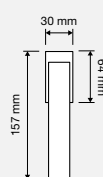

Sintesi Mart

COLLEZIONE 2010
2010 COLLECTION

La particolarità di un inserto in vetro realizzato artigianalmente risulta essere una piacevole digressione di stile alle forme semplici e rigorose di questa collezione.

The particularity of a handmade glass insert is a pleasant diversion in style to the simple and meticulous forms of this collection.

ONLY MADE IN ITALY

PATENTED
DESIGN





SINTESI MART | FINITURE / FINISHINGS



CR cromo lucido
polished chrome



OZ oro zecchino
gold plated

SINTESI MART | FANTASIE / FANTASY



1302 vetro fantasia blu
M15 *blue fantasy glass*



1303 vetro fantasia marrone
M16 *brown fantasy glass*



COD. 1302 RB 019

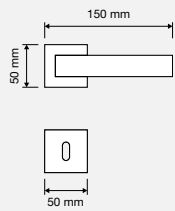

COD. 1302 DK

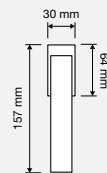

COD. 1302 MN 282

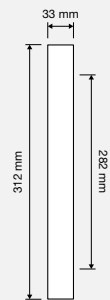

COD. 1302 PT

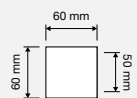

COLLEZIONE 2010
2010 COLLECTION

Sintesi wengé

Il fascino del legno pregiato proveniente dalle foreste tropicali dona un tocco quasi esotico a questa collezione, caratterizzata da linee estremamente semplici e pulite.

The fascination of precious wood from tropical forests gives this collection an almost exotic taste, characterised by extremely simple and clean lines.

ONLY MADE IN ITALY

PATENTED
DESIGN





CR cromo lucido
polished chrome



CS cromo satinato
satin chrome



OZ oro zecchino
gold plated



COD. 1304 RB 019

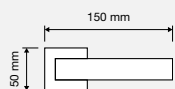

Slim

COLLEZIONE 2006
2006 COLLECTION

Un gioco di forme e volumi differenti contraddistingue il design di questa collezione che gioca con le differenti proporzioni di ogni sua componente.

A combination of different forms and volumes characterises the design of this collection that plays with the different proportions of each component.

ONLY MADE IN ITALY

PATENTED
DESIGN





SLIM | FINITURE / FINISHINGS

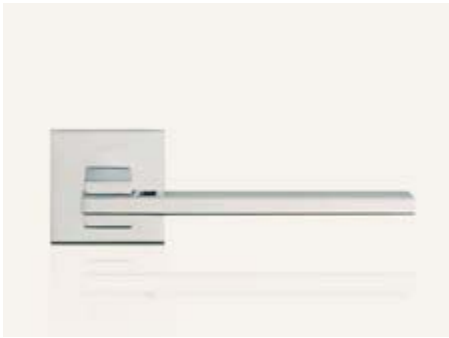

CR cromo lucido
polished chrome



CS cromo satinato
satin chrome

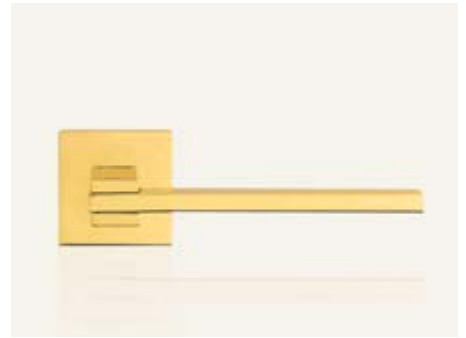

OL ottone lucido verniciato
polished brass



OS ottone satinato
satin brass

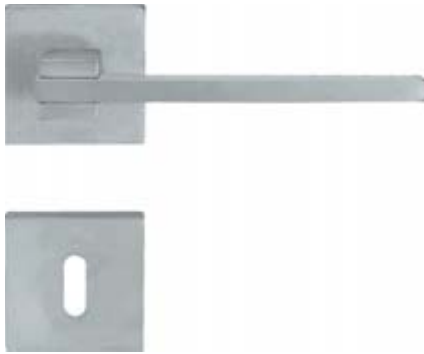

COD. 1110 RB 019

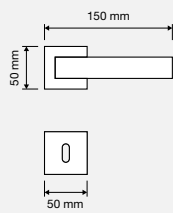

COD. 1110 PL

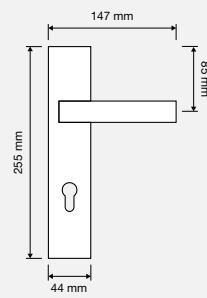

COD. 1110 MZ 240*

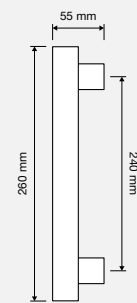

COD. 1110 MN 240*

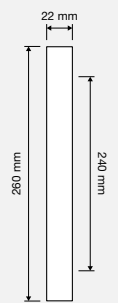

* Interassi disponibili / available distances
240 - 300 - 400 - 600 - 800



COD. 1110 DK

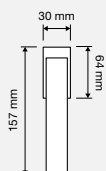

Slim pelle

COLLEZIONE 2006
2006 COLLECTION

Il gioco di forme e volumi differenti dal sapore particolarmente moderno viene reso più classico grazie all'impugnatura rivestita in vera pelle italiana, naturale espressione della lavorazione artistica del pellame.

The combination of different forms and volumes with a particularly modern taste is made more classical in style thanks to the handgrip covered with real Italian leather, a natural expression of the artistic handcrafting of leather.

ONLY MADE IN ITALY

PATENTED
DESIGN





SLIM PELLE | FINITURE / FINISHINGS



CR cromo lucido
polished chrome



OZ oro zecchino
gold plated

SLIM PELLE | FANTASIE / FANTASY



1111 pelle nera
black leather



1112 pelle marrone
brown leather



COD. 1111 RB 019

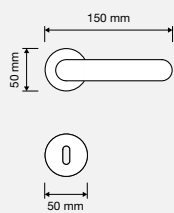

COD. 1111 PL

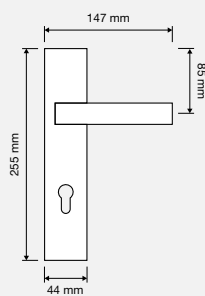

COD. 1111 MZ 240*

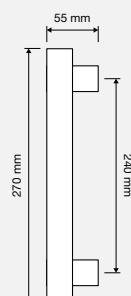

COD. 1111 MN 240*



* Interassi disponibili / available distances
240 - 300 - 400 - 600 - 800



COD. 1111 DK

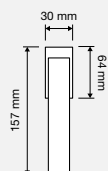

Star

COLLEZIONE 2013
2013 COLLECTION

design by
Dmitry Kozinenko

Se ne può riassumere l'essenza con una parola: movimento. Infatti, sebbene "la stella" sia in posizione statica, sembra che si muova verso mondi lontani.

Its essence can be captured with one word: movement. Indeed, even though "the star" is in a static position, it seems to be moving to far off lands.

ONLY MADE IN ITALY

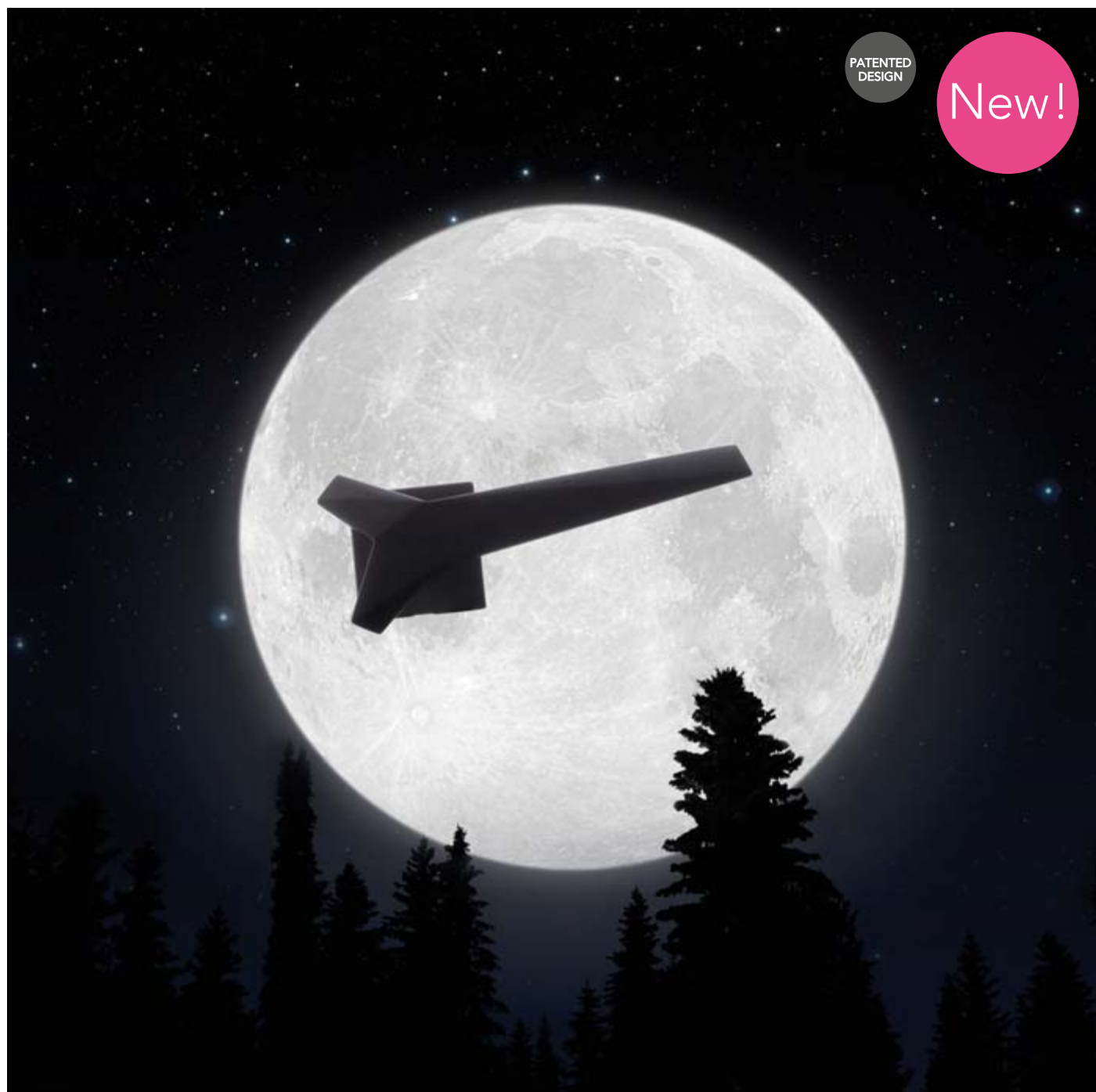

PATENTED
DESIGN

New!



CR cromo lucido
polished chrome



CS cromo satinato
satin chrome



MC cromo + cromo sabbato
chrome + matt chrome mix



OM oro + oro sabbato
polished gold + matt gold mix



OZ oro zecchino
gold plated



VE nero opaco
matt black



COD. 690 RB 019

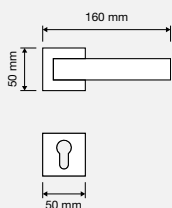

COD. 690 DK

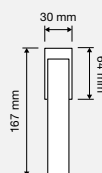

COLLEZIONE 2007
2007 COLLECTION

Thais

Una leggerissima scanalatura, appena percettibile agli occhi e sotto il palmo della mano, dona un sapore piacevolmente insolito a una collezione che fa della sua semplicità il suo punto di forza.

A very slight groove, barely visible to the eye and under the palm of the hand, gives a pleasantly unusual taste to a collection that makes its simplicity its strong point.

ONLY MADE IN ITALY





THAIS | FINITURE / FINISHINGS



CC cromo satinato + cromo
satin chrome + polished chrome mix



CR cromo lucido
polished chrome



CS cromo satinato
satin chrome



OT ottone satinato + ottone lucido
satin brass + polished brass mix



COD. 1155 RB 019

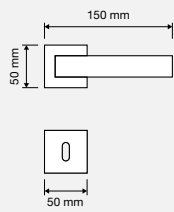

COD. 1155 RB 090

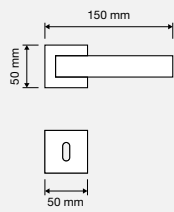

COD. 1155 MN 282

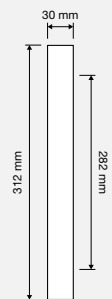

COD. 1155 DK

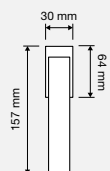

Trendy

COLLEZIONE 2001
2001 COLLECTION

La semplicità delle forme raggiunge l'espressione più elevata in questa collezione che si distingue per la sua estrema leggerezza del design, risultando così un complemento d'arredo passe-partout.

The simplicity of forms reaches its highest expression in this collection that is distinguished by the extreme lightness of its design, making it a passe-partout accessory.

ONLY MADE IN ITALY

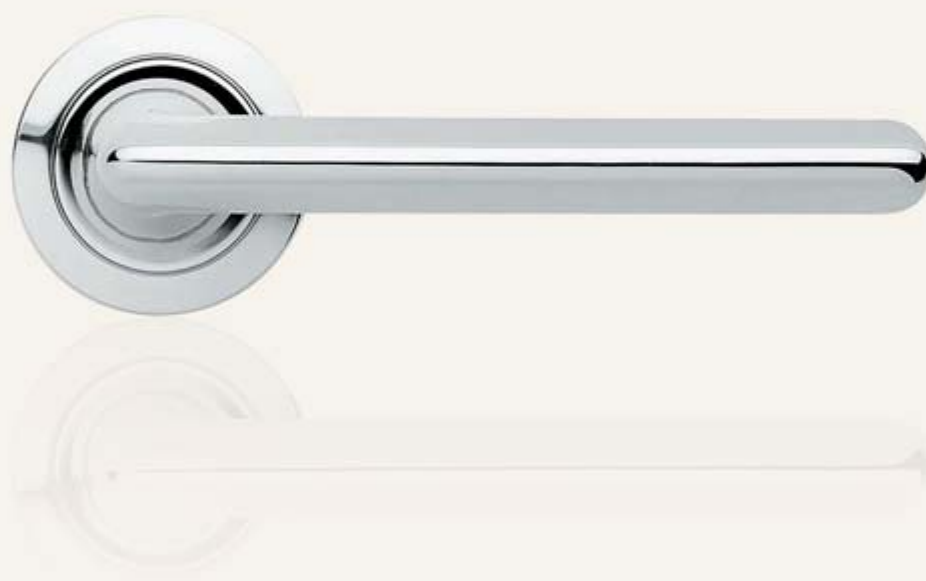



CR cromo lucido
polished chrome



CS cromo satinato
satin chrome



OL ottone lucido verniciato
polished brass



COD. 980 RB 102

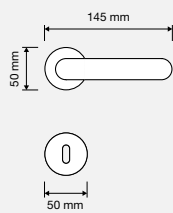

COD. 980 RB 019

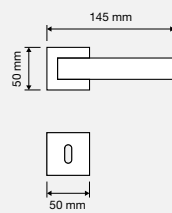

COD. 980 DK

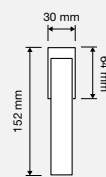

L'espressione del design moderno più classico e lineare è alla base del concept stilistico di questa collezione che si contraddistingue per l'estrema linearità delle forme.

An expression of a more classic and linear modern design is the basis for the style concept of this collection that stands out by the extremely linear forms.

ONLY MADE IN ITALY





CR cromo lucido
polished chrome



CS cromo satinato
satin chrome



OL ottone lucido verniciato
polished brass



COD. 1156 RB 019

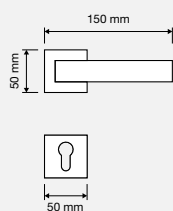

COD. 1156 RB 090

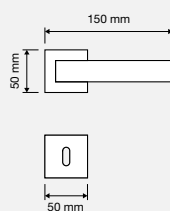

COD. 1156 PL

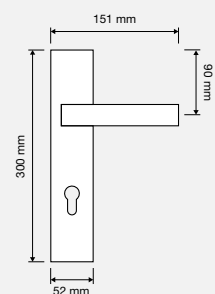

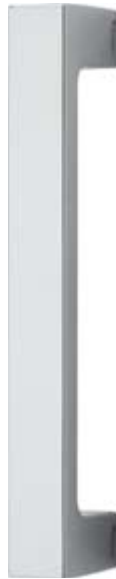

COD. 1156 DK

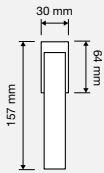

COD. 1156 MN 180

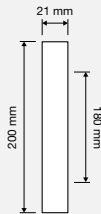

COD. 1156 MN 282

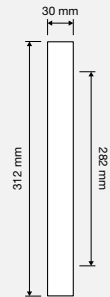

COD. 1156 AB

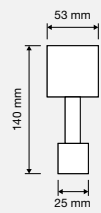

COLLEZIONE 2007
2007 COLLECTION

Zen Wengé

Un inserto di legno pregiato proveniente dalle foreste tropicali rende classica ma insolita questa collezione che nasce come espressione del design moderno.

An insert in precious wood originating in the tropical forests makes this collection classical and unusual which was created as an expression of modern design.

ONLY MADE IN ITALY





ZEN WENGÉ | FINITURE / FINISHINGS



CR cromo lucido
polished chrome



CS cromo satinato
satin chrome



OZ oro zecchino
gold plated



COD. 1158 RB 019

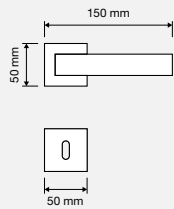

COD. 1158 PL

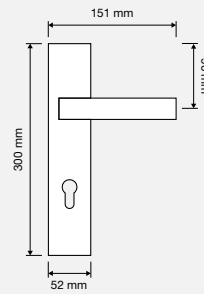

COD. 1158 MN 282

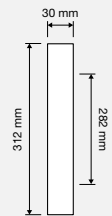

COD. 1158 DK

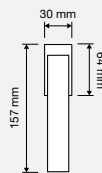



Classic

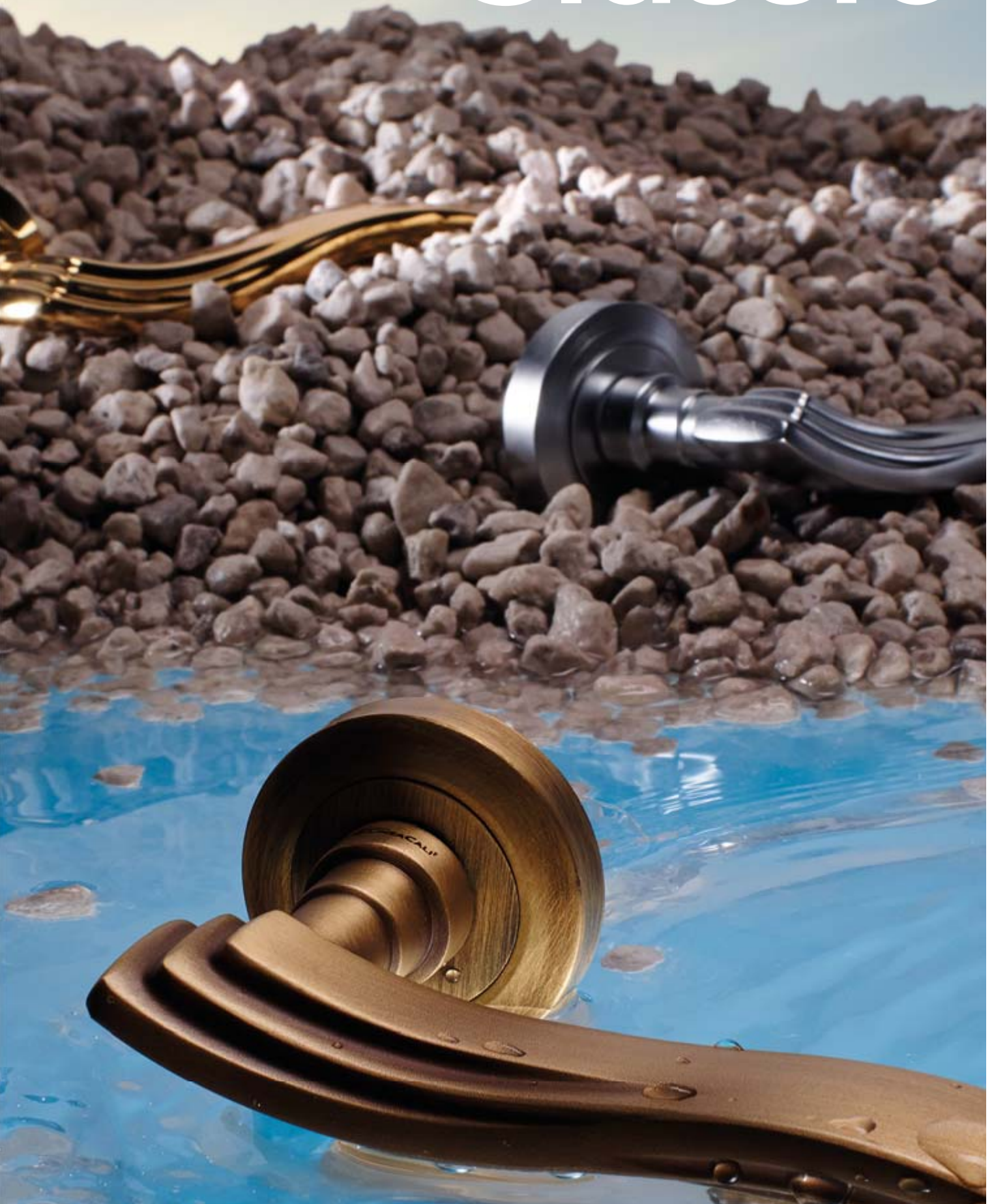

Aldar

COLLEZIONE 1990
1990 COLLECTION

Le forme morbide e gentili di questa collezione donano un tocco classico e piacevolmente femminile ad ogni ambiente.

The soft and gentle forms of this collection give a classical and pleasantly feminine touch to all surroundings.

ONLY MADE IN ITALY





AN *ottone invecchiato*
aged brass



OG *ottone bronzato graffiato*
bronzed brass



OL *ottone lucido verniciato*
polished brass



OM *oro + oro sabbato*
polished gold + matt gold mix



COD. 920 RB 103

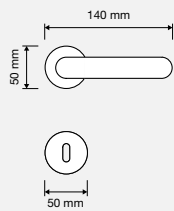

COD. 920 CR

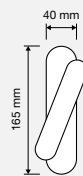

COD. 920 MN 218

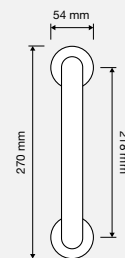

COD. 920 MN 315

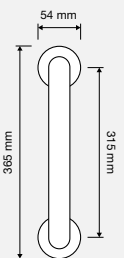

COD. 920 MX

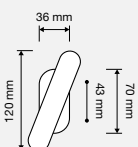

COLLEZIONE 2009
2009 COLLECTION

Dafne

Una nuova rivisitazione del classico descritta dal profilo leggermente arcuato e sfuggente dell'impugnatura, ideale passe-partout per ogni ambiente.

A new reinterpretation of the classic handle characterised by the slightly arched and elusive profile of the handgrip, the ideal passe-partout in all surroundings.

ONLY MADE IN ITALY

PATENTED
DESIGN





DAFNE | FINITURE / FINISHINGS



CR cromo lucido
polished chrome



CS cromo satinato
satin chrome



OL ottone lucido verniciato
polished brass



PM patiné
patiné mat



COD. 509 RB 102

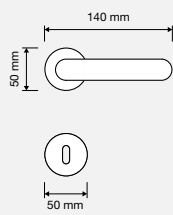

COD. 509 RB 019

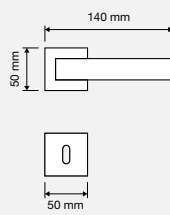

COD. 509 PL

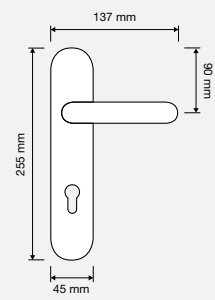

COD. 509 DK

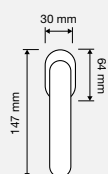

Dalia

COLLEZIONE 1990
1990 COLLECTION

Caratterizzata da un'impugnatura realizzata in ceramica dalla forma delicata, Dalia porta un tocco di femminilità in ogni ambiente.

Characterised by the delicate form of the handle made of ceramic, Dalia adds a touch of femininity to all rooms.

ONLY MADE IN ITALY





AN ottone invecchiato
aged brass



BM bronzo opaco
matt bronze



FV ferro effetto invecchiato
aged iron (brass)



OG ottone bronzato graffiato
bronzed brass



OL ottone lucido verniciato
polished brass

DALIA | FANTASIE / FANTASY



PB porcellana bianca
600 *white porcelain*



BR porcellana bianca fiore rosa
660 *pink rose flowered white porcelain*



BB porcellana bianca fiore blu
661 *blue rose flowered white porcelain*



PA porcellana beige
602 *ivory porcelain*



AR porcellana beige fiore rosa
766 *pink rose flowered ivory porcelain*



AM porcellana beige fiore marrone
665 *brown flowered ivory porcelain*



COD. 600 RB 102

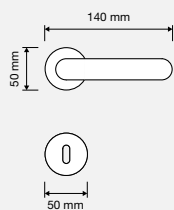

COD. 600 PL

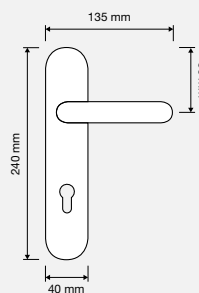

COD. 600 MN 218

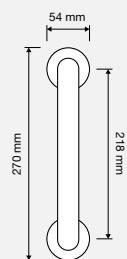

COD. 600 DK

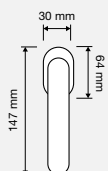

COD. 600 MX

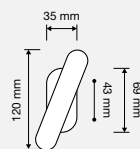

COD. 600 CR

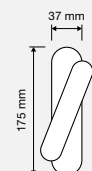

COLLEZIONE 2002
2002 COLLECTION

Delfino

Linee fluide scivolano fra le dita e danno vita a una forma particolare che discende dall'ambiente marino e che suscita curiosità.

Flowing lines glide beneath our fingers and give life to a particular shape that originates in the marine environment and arouses our curiosity.

ONLY MADE IN ITALY

PATENTED
DESIGN





BM bronzo opaco
matt bronze



CS cromo satinato
satin chrome



MC cromo + cromo sabbato
chrome + matt chrome mix



OL ottone lucido verniciato
polished brass



OM oro + oro sabbato
polished gold + matt gold mix

DELFINO | MODELLI / MODELS



COD. 955 DK

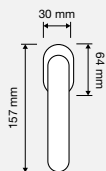

COD. 955 CR



COD. 955 PT

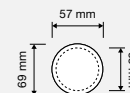

COD. 955 PG 102

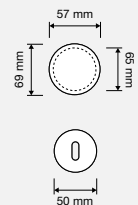



COD. 955 RB 102

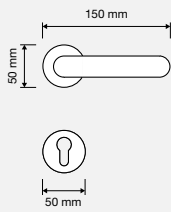

COD. 955 PL

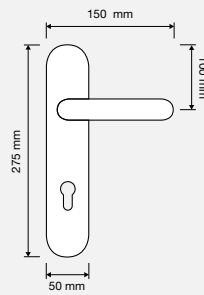

COD. 955 MN 240

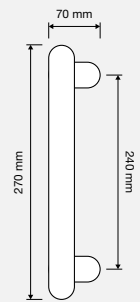

COD. 955 MX

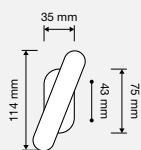

COD. 542 CH

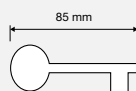

Elika

COLLEZIONE 2003
2003 COLLECTION

Linee sfuggenti donano un'inaspettata dinamicità a questa collezione, resa ancor più attraente dall'abbinamento insolito delle finiture che ne esaltano la forma.

Elusive lines give this collection an unexpected vitality, made even more attractive by the unusual combination of finishes that enhance the shape.

ONLY MADE IN ITALY

PATENTED
DESIGN





BM bronzo opaco
matt bronze



MC cromo + cromo sabbiato
chrome + matt chrome mix



OM oro + oro sabbiato
polished gold + matt gold mix



COD. 990 RB 108

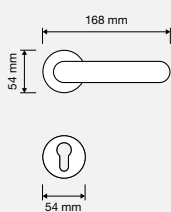

COD. 990 PL

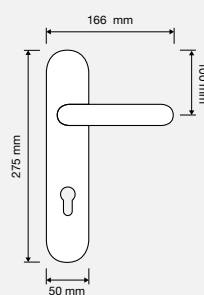

COD. 990 MN 275

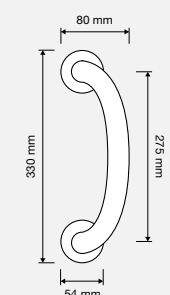



COD. 990 DK

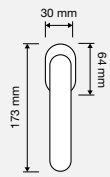

COD. 990 MX

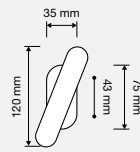

COD. 990 CR

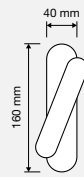

COD. 990 BA

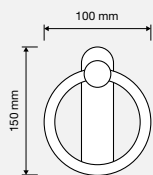

COD. 990 PT

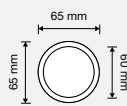

COD. 990 PG 108

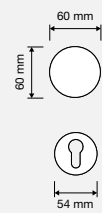

L'attualissimo stile shabby-chic, che combina lo stile provenzale a quello british e retrò, vede come ideale complemento d'arredo questa collezione dalle forme piacevolmente femminili.

The recent shabby-chic style, that combines the Provençal style with the British retro style, makes this collection with pleasantly feminine forms the ideal furnishing accessory.

ONLY MADE IN ITALY





AN ottone invecchiato
aged brass



BM bronzo opaco
matt bronze



OG ottone bronzato graffiato
bronzed brass



OL ottone lucido verniciato
polished brass



PB porcellana bianca
1295 *white porcelain*



PA porcellana beige
1296 *ivory porcelain*



COD. 1295 RB 103

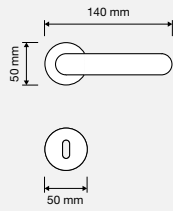

COD. 1295 PL

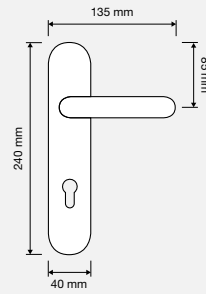

COD. 1295 MN 218

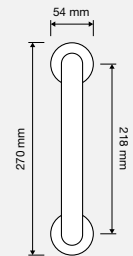

COD. 1295 DK

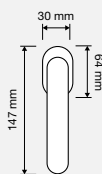

Flavia

COLLEZIONE 1990
1990 COLLECTION

Delicati e raffinati motivi floreali disegnano la pregiata porcellana italiana che caratterizza così questa collezione da un piacevole sapore retrò.

Delicate and refined floral motifs adorn this fine Italian porcelain that characterises this collection with a pleasantly retro taste.

ONLY MADE IN ITALY





AN ottone invecchiato
aged brass



BM bronzo opaco
matt bronze



OG ottone bronzato graffiato
bronzed brass



OL ottone lucido verniciato
polished brass



PB porcellana bianca
685 *white porcelain*



BR porcellana bianca fiore rosa
680 *pink rose flowered white porcelain*



BB porcellana bianca fiore blu
681 *blue rose flowered white porcelain*



PA porcellana beige
687 *ivory porcelain*



AR porcellana beige fiore rosa
767 *pink rose flowered ivory porcelain*



AM porcellana beige fiore marrone
683 *brown flowered ivory porcelain*



PF porcellana bianca margherita
686 *daisy flowered white porcelain*



FLAVIA | MODELLI / MODELS



COD. 685 RO102



COD. 685 RB 102



COD. 685 CR

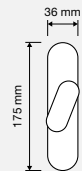

COLLEZIONE 2006
2006 COLLECTION

Havana

Linee curve si rincorrono dando vita a una silhouette estremamente dolce, caratterizzata da un alternarsi di superfici lucide e satinate, che vuole essere un omaggio al famosissimo sigaro cubano.

Curved lines follow one another giving life to an extremely sweet silhouette, characterized by alternating polished and satin surfaces, that is a tribute to the famous Cuban cigar.

ONLY MADE IN ITALY

PATENTED
DESIGN





CP cromo perla
pearl chrome



CR cromo lucido
polished chrome



OL ottone lucido verniciato
polished brass



OL ottone lucido verniciato
polished brass



OM oro + oro sabbato
polished gold + matt gold mix



OZ oro zecchino
gold plated



1081 legno di rosa
rose wood



COD. 1080 RB 102

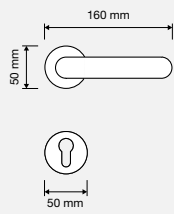

COD. 1080 PL

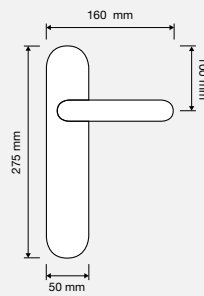

COD. 1080 MN 267

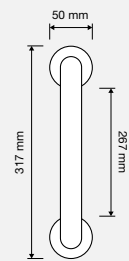

COD. 1080 DK

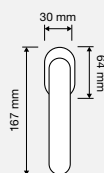

Karina

COLLEZIONE 1998
1998 COLLECTION

Gli stilemi del design anni '80 e le ardite finiture rendono questa collezione la scelta ideale in tutti quegli ambienti che necessitano di quel tocco in più che solo una maniglia di stile può dare.

The stylistic design of the 80s and the daring finishes make this collection the ideal choice in all environments that need that extra touch that only a stylish handle can give.

ONLY MADE IN ITALY





CE nero opaco + cromo
matt black + polished chrome mix



CN nickel satinato + cromo
satin nickel + polished chrome mix



OC cromo + ottone lucido
chrome + polished brass mix



OT ottone satinato + ottone lucido
satin brass + polished brass mix



KARINA | MODELLI / MODELS



COD. 940 RB 102

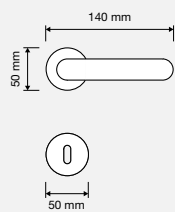

COD. 940 PL

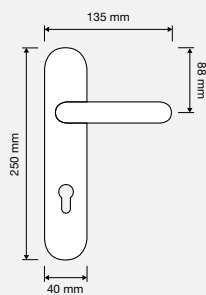

COD. 940 DK

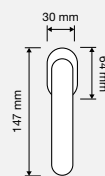

COLLEZIONE 1998
1998 COLLECTION

Kuba

Forme importanti, caratterizzate da linee morbide e dolci, rendono questa collezione insolita e divertente. Un interessante e particolare gioco di stile.

Imposing shapes, characterised by soft and gentle lines, make this an unusual and fun collection. An interesting and particular style.

ONLY MADE IN ITALY





KUBA | FINITURE / FINISHINGS



CR cromo lucido
polished chrome



CS cromo satinato
satin chrome



NS nickel satinato
satin nickel



OL ottone lucido verniciato
polished brass



OZ oro zecchino
gold plated



COD. 930 RB 103

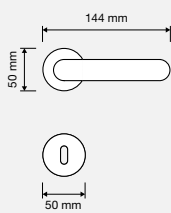

COD. 930 PL

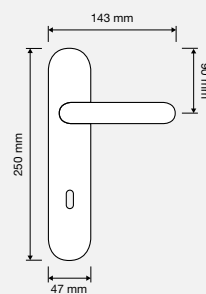

COD. 930 DK

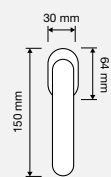

Kuba pomolo

COLLEZIONE 1998
1998 COLLECTION

Una forma naturale, materica, che ricorda una pietra modellata dall'acqua e che risulta estremamente piacevole da impugnare.

A natural and material form, that recalls a stone that has been modelled by water and is extremely pleasant to hold.

ONLY MADE IN ITALY





CR cromo lucido
polished chrome



CS cromo satinato
satin chrome



NS nickel satinato
satin nickel



OL ottone lucido verniciato
polished brass



PV titanio
titanium



COD. 936 RB 103

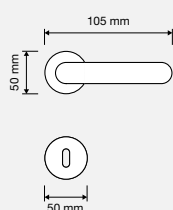

Lady

COLLEZIONE 2012
2012 COLLECTION

Una forma caratterizzata da linee dolci ed equilibrate, ispirate esplicitamente alla bellezza femminile.

A shape characterised by soft and balanced lines, inspired expressly by feminine beauty.

ONLY MADE IN ITALY

PATENTED
DESIGN





BO bronzo sfumato opaco
bronze



OF oro francese
french gold



OL ottone lucido verniciato
polished brass



OZ oro zecchino
gold plated



LADY | MODELLI / MODELS



COD. 1390 RB 011

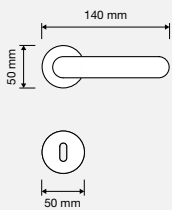

COD. 1390 PL

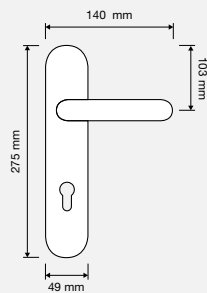

COLLEZIONE 2001
2001 COLLECTION

Libera

La sensazione di libertà è chiara ed evidente nelle forme che sembrano essere modellate dal vento.

The sensation of liberty is clear and evident in the forms that seem to have been shaped by the wind.

ONLY MADE IN ITALY





BM bronzo opaco
matt bronze



NS nickel satinato
satin nickel



OG ottone bronzato graffiato
bronzed brass



OL ottone lucido verniciato
polished brass



OS ottone satinato
satin brass



COD. 981 MX

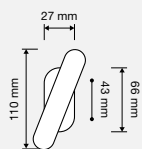

COD. 981 CR

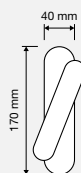



COD. 981 RB 103

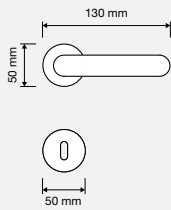

COD. 981 PL

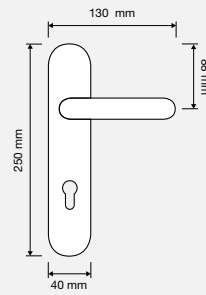

COD. 981 DK

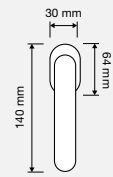

Marina

COLLEZIONE 2008
2008 COLLECTION

Una vera maniglia di stile e uno dei best-sellers di Linea Cali, caratterizzata da una triplice onda che rende l'impugnatura comoda e allo stesso tempo regala un senso di dinamicità alle forme.

A truly stylish handle and one of Linea Cali's best sellers, characterised by a triple wave that makes the handgrip comfortable and at the same time gives the forms a sense of vitality.

ONLY MADE IN ITALY

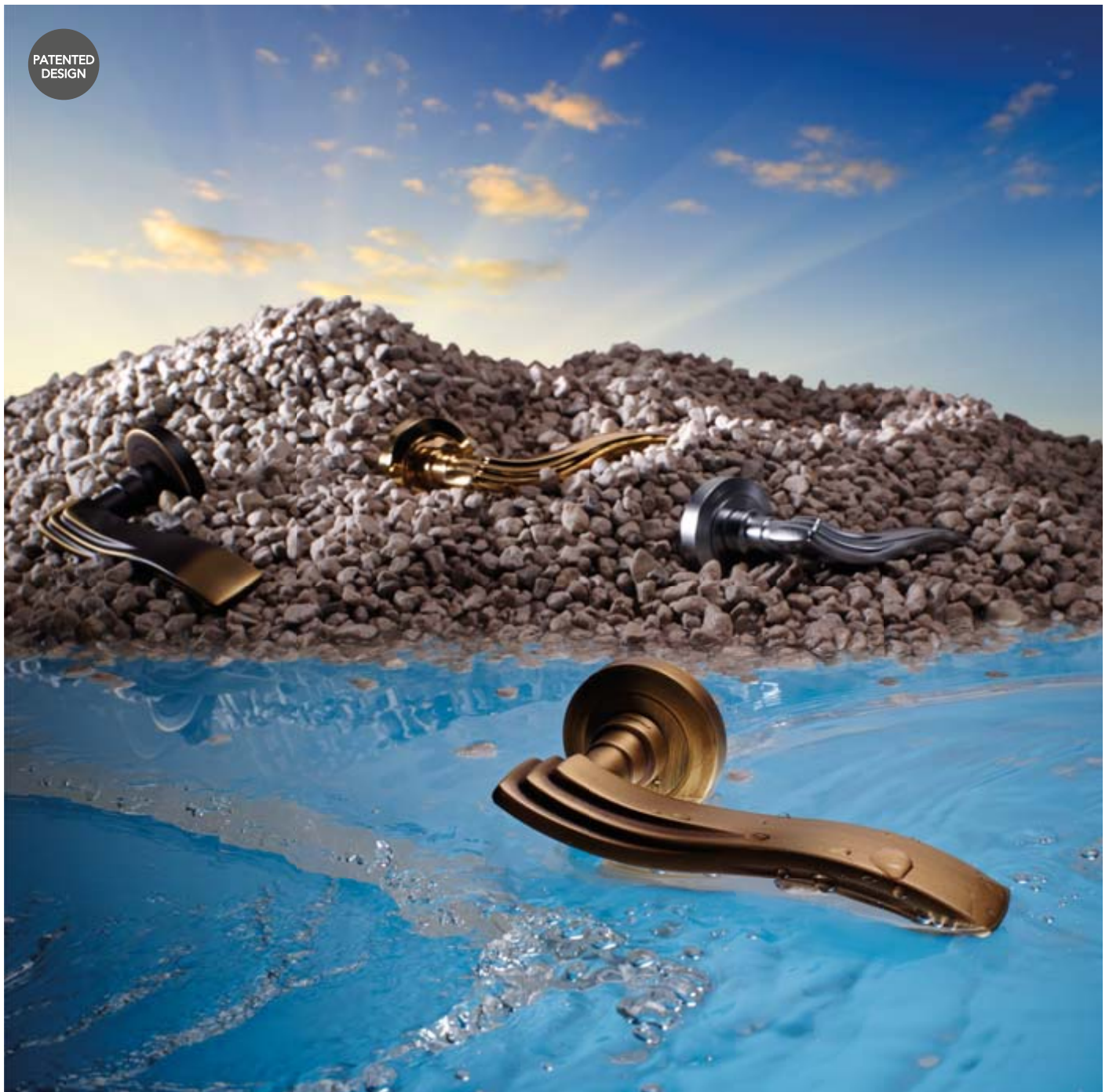



MARINA | FINITURE / FINISHINGS



BM bronzo opaco
matt bronze



CR cromo lucido
polished chrome



CS cromo satinato
satin chrome



OL ottone lucido verniciato
polished brass



PM patiné
patiné mat



COD. 755 RB 102

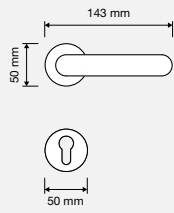

COD. 755 PL

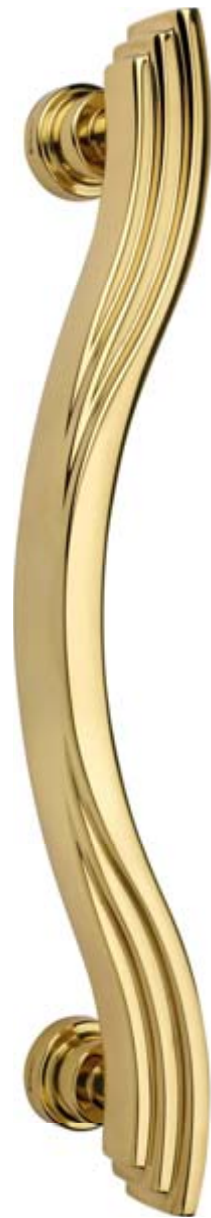
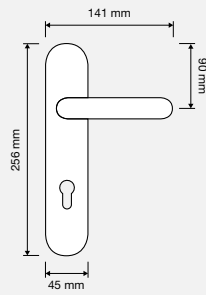

COD. 755 MN 320

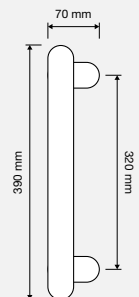

COD. 755 DK

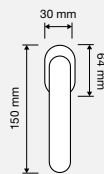

Una rilettura in chiave moderna di una melodia classica, caratterizzata dalla particolarissima impugnatura a forma di nota che rende questa collezione allegra e divertente.

A modern reinterpretation of a classic melody, characterized by the very unusual handgrip in the form of a musical note making this a cheerful and fun collection.

ONLY MADE IN ITALY

PATENTED
DESIGN





NOTA | FINITURE / FINISHINGS



CR cromo lucido
polished chrome



CS cromo satinato
satin chrome



OL ottone lucido verniciato
polished brass



PM patiné
patiné mat



NOTA | MODELLI / MODELS



COD. 1330 RB 103

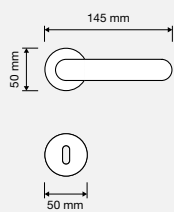

COD. 1330 PL

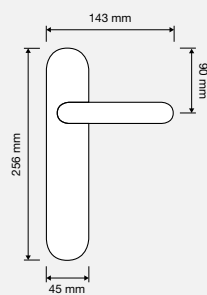

COD. 1330 DK

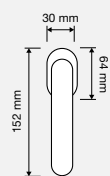

Pin-up

COLLEZIONE 1999
1999 COLLECTION

Le forme delle pin-up tanto in voga sulle riviste americane di un tempo, sono rievocate in questa particolare collezione quanto mai attuale.

The forms of the pin-up girls that were once so fashionable on American magazines are evoked in this particular and extremely modern collection.

ONLY MADE IN ITALY





PIN-UP | FINITURE / FINISHINGS



CR cromo lucido
polished chrome



CS cromo satinato
satin chrome



NS nickel satinato
satin nickel



OL ottone lucido verniciato
polished brass



OS ottone satinato
satin brass



PV titanio
titanium



COD. 925 RB 102

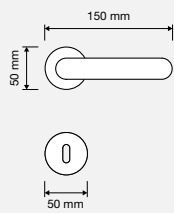

COD. 925 PL

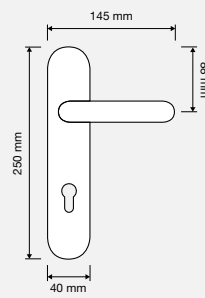

COD. 925 DK

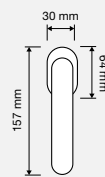

COD. 925 CR

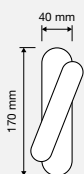

L'apoteosi del comfort. Particolari anelli "accolgono" le dita adattandosi ad ogni tipologia di mano.

Particular "rings" receive the fingers thus adapting itself to all types of hands.

ONLY MADE IN ITALY

PATENTED
DESIGN





CP-BL cromo perla + blu
1031 *pearl chrome + blue*



CP-CR cromo perla + cromo lucido
1002 *pearl chrome + polished chrome*



CP-TU cromo perla + turchese
1030 *pearl chrome + turquoise*



CR-LU cromo lucido + fosforescente
1023 *polished chrome + phosphorescent*



CR-NE cromo lucido + nero
1022 *polished chrome + black*



OZ-OM oro zecchino + oro sabbato
1001 *gold plated + matt gold*



OZ-PC oro zecchino + polvere oro
1014 *gold plated + stardust*



OZ-RA oro zecchino + radica
1013 *gold plated + briarwood*



COD. 1001 RB 108

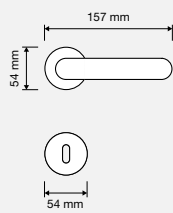

COD. 1001 PL

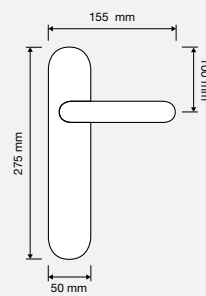

COD. 1001 MN 200
* Interassi disponibili / available distances
150 - 200 - 250 - 300

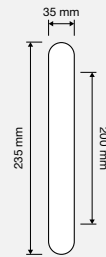

COD. 1001 DK

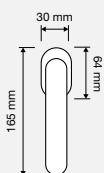

COD. 1001 CR

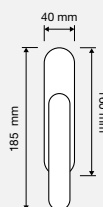

Rose

COLLEZIONE 2003
2003 COLLECTION

Il "sapore" delicato e romantico della rosa Bonica regala un tocco di piacevole femminilità a questa collezione, ideale complemento d'arredo per tutti quegli ambienti dal sapore country e shabby-chic.

The dainty and romantic Bonica rose gives this collection a pleasant femininity, ideal furnishing accessory for all country and shabby-chic decors.

ONLY MADE IN ITALY

PATENTED
DESIGN





AN ottone invecchiato
aged brass



BM bronzo opaco
matt bronze



FV ferro effetto invecchiato
aged iron (brass)



COD. 996 RB 108

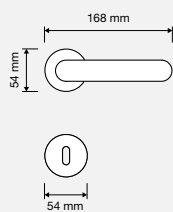

COD. 996 PL

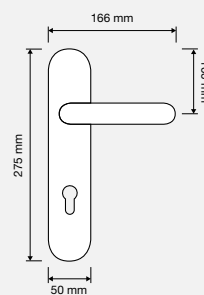

COD. 996 DK

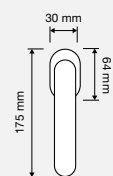



COD. 996 MX

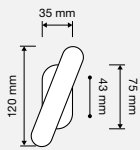

COD. 996 CR



COD. 996 BA

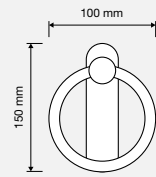

COD. 996 PT

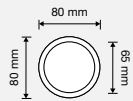

COD. 996 PG 108

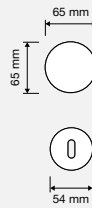

COD. 996 PB





COD. 996 KD-KS

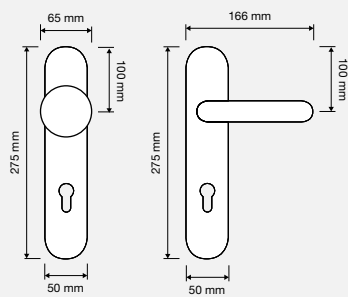

COD. 996 MN 275

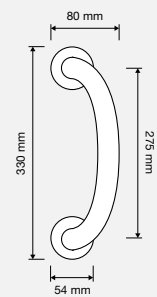

Sirena

COLLEZIONE 1993
1993 COLLECTION

Le morbide forme di Partenope, sirena dalla splendida voce il cui corpo fu portato dalle correnti marine fra gli scogli di Megaride in seguito al rifiuto di Ulisse, accarezzano il palmo della mano incantandola come una sirena.

The soft forms of Parthenope, a mermaid with a splendid voice whose body was washed up on the shores of Megaride after Ulysses' refusal, caress the palm of the hand, enchanting it like a mermaid.

ONLY MADE IN ITALY

PATENTED
DESIGN





AN ottone invecchiato
aged brass



OL ottone lucido verniciato
polished brass



OZ oro zecchino
gold plated



COD. 810 RB 103

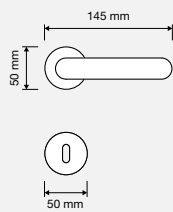

COD. 810 PL

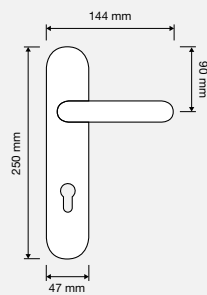

COD. 810 DK

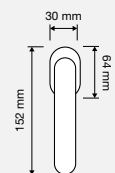



COD. 810 PT

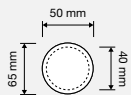

COD. 810 PG 103

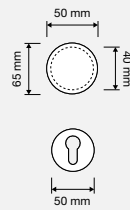

COD. 810 MN 207

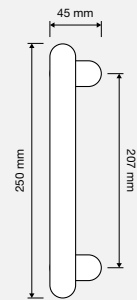

COD. 810 MX

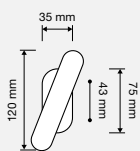

COD. 810 CR



Una collezione estremamente contemporanea, classica ma che strizza l'occhio al design, caratterizzata da uno stile piacevolmente sobrio.

An extremely contemporary collection, classical while winking at design, characterised by a pleasantly sober style.

ONLY MADE IN ITALY





CC cromo satinato + cromo
satin chrome + polished chrome mix

OT ottone satinato + ottone lucido
satin brass + polished brass mix

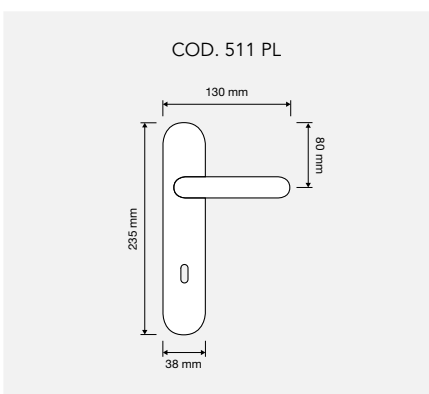
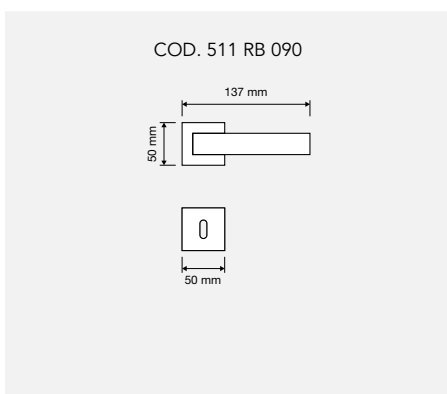
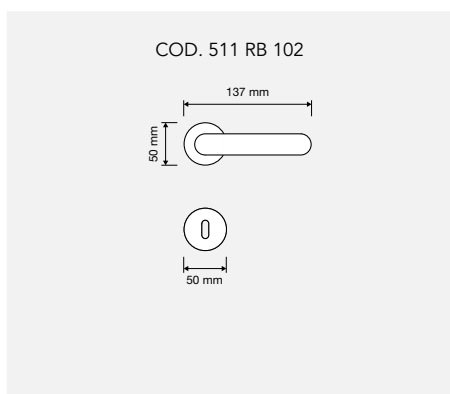



COD. 511 DK

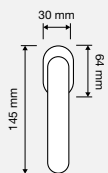

COD. 511 CR



Le atmosfere fresche ma allo stesso tempo sensuali dello stile provenzale, nato nella parte meridionale della Francia fra le Alpi e il mare, donano a questa collezione un "allure" particolarmente romantica.

The fresh but at the same time sensual atmosphere of the Provençal style, created in the south of France between the Alps and the sea, gives this collection a particularly romantic allure.

ONLY MADE IN ITALY





TOSCA | FINITURE / FINISHINGS



AN ottone invecchiato
aged brass



BM bronzo opaco
matt bronze



FV ferro effetto invecchiato
aged iron (brass)



OL ottone lucido verniciato
polished brass



COD. 745 RB 110

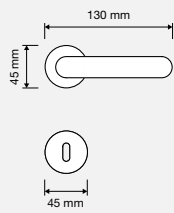

COD. 745 PL

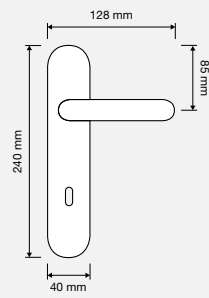

COD. 745 DK

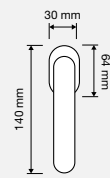



COD. 745 CR

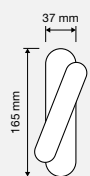

COD. 745 MN 158

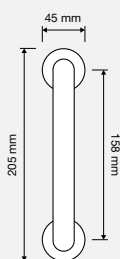

COD. 745 MN 225

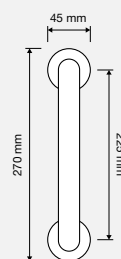

COD. 745 MX

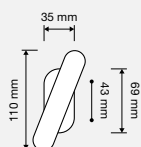

Vola

COLLEZIONE 2005
2005 COLLECTION

Una forma plasmata dal vento che ricorda vagamente la sella del cavallo Seabiscuit, il famoso purosangue americano che nel 1938 venne definito il personaggio più famoso dell'anno.

A form shaped by the wind that vaguely reminds us of the horse, Seabiscuit, the famous American thoroughbred which, in 1938, was defined the most famous personality of the year.

ONLY MADE IN ITALY

PATENTED
DESIGN





AN *ottone invecchiato*
aged brass



BM *bronzo opaco*
matt bronze



CR *cromo lucido*
polished chrome



CS *cromo satinato*
satin chrome



NS *nickel satinato*
satin nickel



OL *ottone lucido verniciato*
polished brass



COD. 750 RB 103

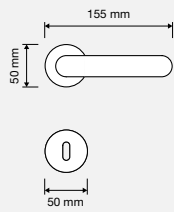

COD. 750 PL

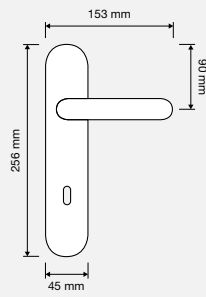

COD. 750 DK

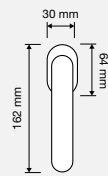

COD. 750 CR

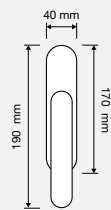





Basic



La semplicità, rappresentata dall'impugnatura esile nel design ma sicura sotto la mano, rende questa collezione un complemento d'arredo estremamente semplice da abbinare.

Simplicity, represented by a handgrip which is slender in design yet firm under the hand, makes this collection a furnishing accessory that fits in everywhere with extreme ease.

ONLY MADE IN ITALY

PATENTED
DESIGN





CR cromo lucido
polished chrome



CS cromo satinato
satin chrome



NS nickel satinato
satin nickel



OG ottone bronzato graffiato
bronzed brass



OL ottone lucido verniciato
polished brass



OS ottone satinato
satin brass



COD. 760 RB 101

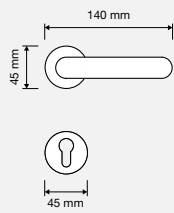

COD. 760 RB 102

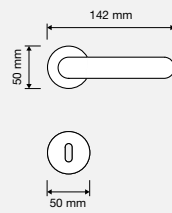

COD. 760 PL

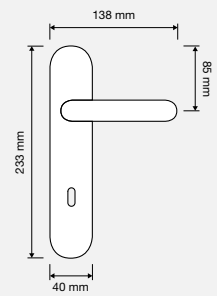

COD. 760 DK

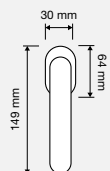

COLLEZIONE 1998
1998 COLLECTION

Garda

La semplicità è alla base di questa collezione, contraddistinta dall'impugnatura particolarmente arrotondata che trasmette una piacevole sensazione alla mano.

Simplicity is at the base of this collection, characterised by the particularly rounded handgrip that transmits a pleasant sensation to the hand.

ONLY MADE IN ITALY





GARDA | FINITURE / FINISHINGS



CR cromo lucido
polished chrome



CS cromo satinato
satin chrome



NS nickel satinato
satin nickel



OG ottone bronzato graffiato
bronzed brass



OL ottone lucido verniciato
polished brass



OS ottone satinato
satin brass



COD. 670 RB 101

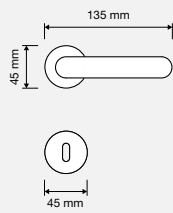

COD. 670 PL

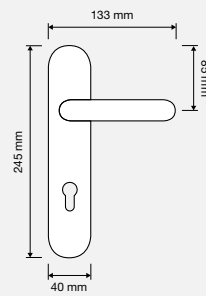

COD. 670 MN 200

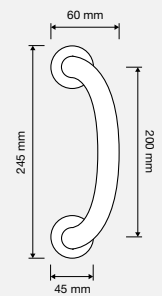

COD. 670 DK

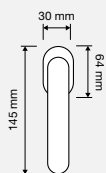

COD. 670 MX

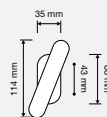

COD. 670 CR



Il mare che bacia la spiaggia di Portinatx è stato l'ispirazione del design dell'impugnatura, modellata come un'onda e che dona un tocco molto personale ad ogni ambiente.

The sea that kisses the beach of Portinatx provided the inspiration for the design of the hand-grip, modelled like a wave and which gives all rooms a personal touch.

ONLY MADE IN ITALY





AN ottone invecchiato
aged brass



FV ferro effetto invecchiato
aged iron (brass)



OG ottone bronzato graffiato
bronzed brass



OL ottone lucido verniciato
polished brass



COD. 545 MX

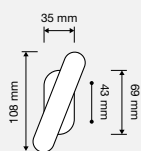

COD. 545 CR





IBIZA | MODELLI / MODELS



COD. 545 RB 101

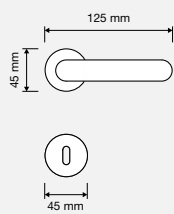

COD. 545 PL

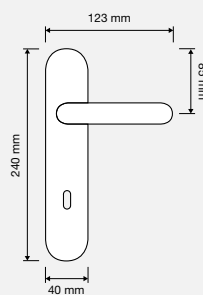

COD. 545 DK

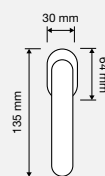

COLLEZIONE 1990
1990 COLLECTION

Mare

Il mare dolce e calmo della baia di Lindos (Grecia) riaffiora alla mente guardando questa collezione elegante e discreta, contraddistinta dall'impugnatura spiovente.

The calm and sweet sea of the bay of Lindos (Greece) comes to mind when admiring this elegant and discreet collection, characterised by the sloping handgrip.

ONLY MADE IN ITALY





MARE | FINITURE / FINISHINGS



CR cromo lucido
polished chrome



CS cromo satinato
satin chrome



OG ottone bronzato graffiato
bronzed brass



OL ottone lucido verniciato
polished brass



OS ottone satinato
satin brass



COD. 710 RB 101

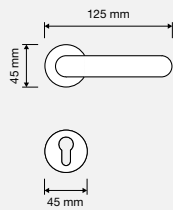

COD. 710 PS

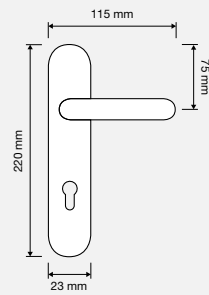

COD. 710 PL

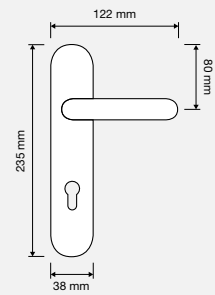

COD. 710 DK

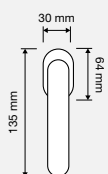

COD. 710 MX

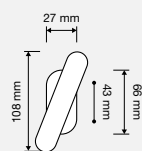

COD. 710 CR



Onda

COLLEZIONE 1986
1986 COLLECTION

Ispirata alle onde e bellezze del Lago di Garda, è contraddistinta dal particolare incavo dell'impugnatura che le dona una presa estremamente sicura e comoda.

Inspired by the waves and beauty of Lake Garda, it is distinguished by the particular recess of the handgrip that gives it an extremely firm and comfortable grasp.

ONLY MADE IN ITALY





BM bronzo opaco
matt bronze



OG ottone bronzato graffiato
bronzed brass



OL ottone lucido verniciato
polished brass



OS ottone satinato
satin brass



COD. 530 MX

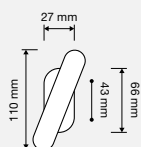

COD. 530 CR





ONDA | MODELLI / MODELS



COD. 530 RB 101

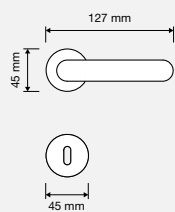

COD. 530 RB 103

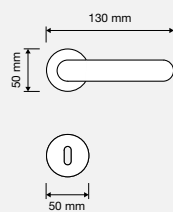

COD. 530 PL

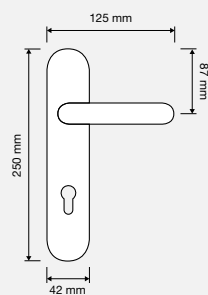

Le cose semplici sono le più difficili da progettare, ma quando ci si riesce il risultato è notevole; così è stato per questa collezione, caratterizzata da linee armoniose che la rendono apparentemente esile ma che consentono una presa sicura e confortevole.

The simplest things are the most difficult to design, but when you succeed the result is striking; so it was for this collection, characterised by harmonious lines that make it seem slight but allow for a firm and comfortable grip.





PIUMA | FINITURE / FINISHINGS



CR cromo lucido
polished chrome



CS cromo satinato
satin chrome



OG ottone bronzato graffiato
bronzed brass



OL ottone lucido verniciato
polished brass



COD. 1415 RB 101

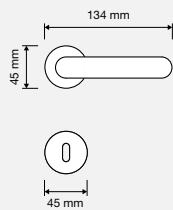

COD. 1415 RB 096

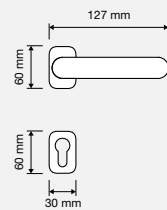

COD. 1415 DK

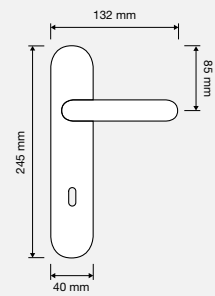

COD. 1415 DK

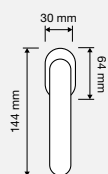

Chi l'ha detto che le maniglie sono tutte uguali? Ne è la prova questa ampia collezione, studiata in ogni suo particolare così da renderla differente senza inutili esercizi stilistici.

Who said that handles are all the same? This ample collection is anything but, meticulously designed to make it different without any unnecessary styling exercises.

ONLY MADE IN ITALY





OG ottone bronzato graffiato
bronzed brass



OL ottone lucido verniciato
polished brass



COD. 625 RB 101

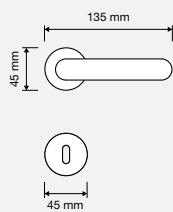

COD. 625 RB 102

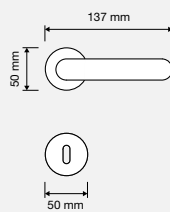

COD. 625 PL

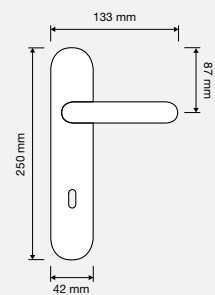



SABA | MODELLI / MODELS



COD. 625 DK

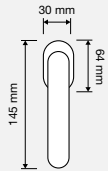

COD. 625 MX

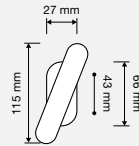

COD. 625 CR









accessori *accessories*

MANIGLIONI / PULL HANDLES

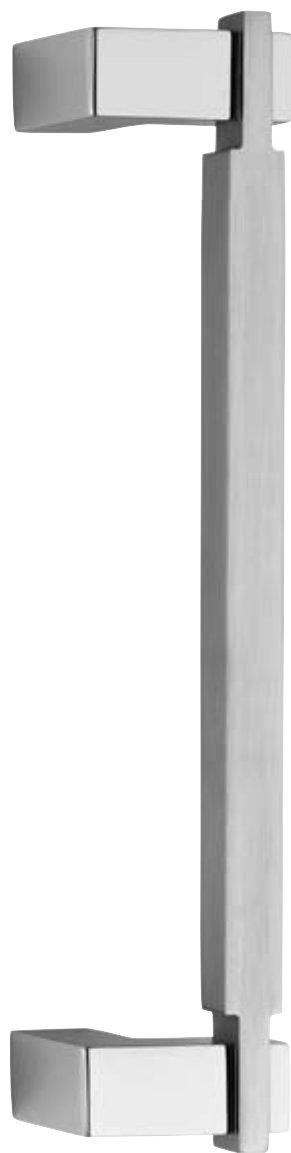

ELLE | COD. 1050 MN 240
Interassi disponibili / available distances
240 - 320 - 440 - 500 - 800

ELLE PELLE | COD. 1052 MN 240

ELLE | COD. 1050 MZ 240
Interassi disponibili / available distances
240 - 320 - 440 - 500 - 800

ELLE PELLE | COD. 1052 MZ 240

CC CR CS



OL OT OZ

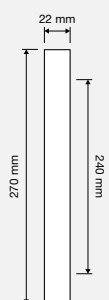
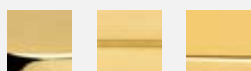

CR CS



OL OZ

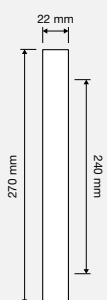

CC CR CS



OL OT OZ

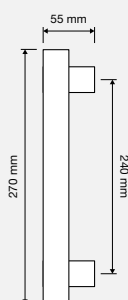
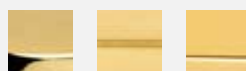

CR CS



OL OZ

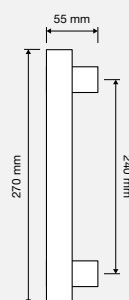

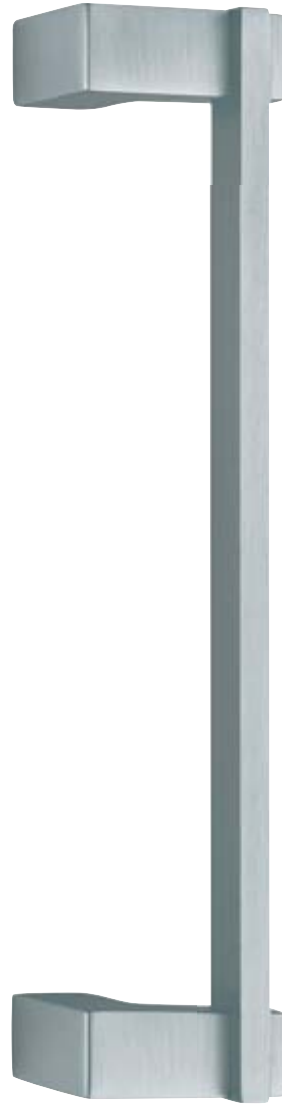

SLIM | COD. 1110 MN 240
Interassi disponibili / available distances
240 - 300 - 400 - 600 - 800

CR	CS
OL	OZ

SLIM PELLE | COD. 1111 MN 240
Interassi disponibili / available distances
240 - 300 - 400 - 600 - 800

CR	OZ

SLIM | COD. 1110 MZ 240
Interassi disponibili / available distances
240 - 300 - 400 - 600 - 800

CR	CS
OL	OZ

SLIM PELLE | COD. 1111 MZ 240
Interassi disponibili / available distances
240 - 300 - 400 - 600 - 800

CR	OZ

MANIGLIONI / PULL HANDLES



ZEN | COD. 1156 MN 282

CR CS OL

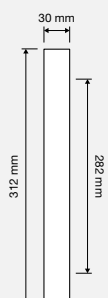

THAIS | COD. 1155 MN 282

CC CR



CS OT

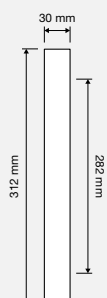

PROFILO | COD. 1040 MN 240

CR CS MC



OL OM

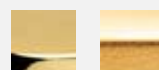



OPEN | COD. 1105 MN 207

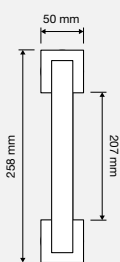
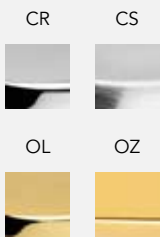

IBIS | COD. 691 MN 300

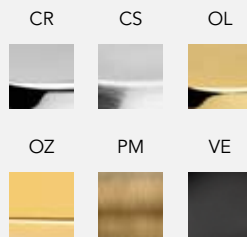

ELIKA | COD. 990 MN 275

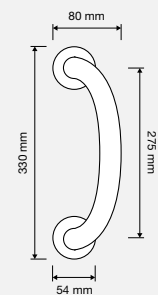
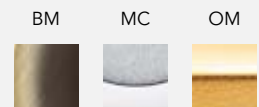

MANIGLIONI / PULL HANDLES



ASIA | COD. 960 MN 200

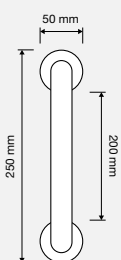
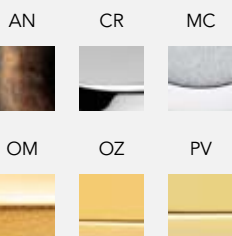

SIRENA | COD. 810 MN 207

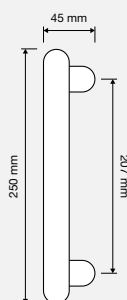
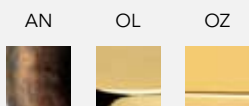

GARDA | COD. 670 MN 200

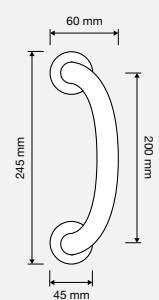
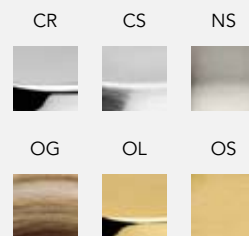



DELFINO | COD. 955 MN 240

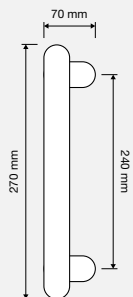
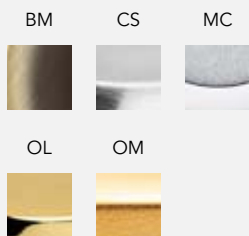

FUTURA | COD. 970 MN 265

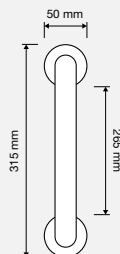
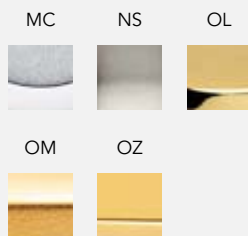

ROSE | COD. 996 MN 275

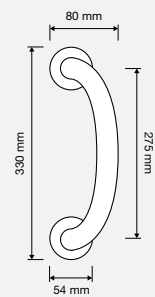
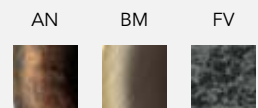

MANIGLIONI / PULL HANDLES



HAVANA | COD. 1080 MN 267

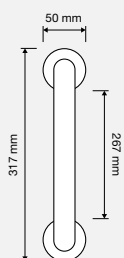
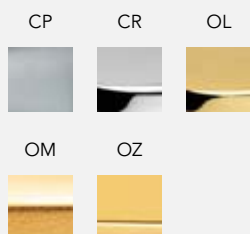

TOSCA | COD. 745 MN 225

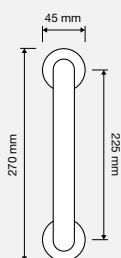
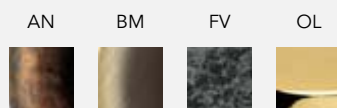

RELAX | COD. 1001 MN 200
Interassi disponibili / available distances
150 - 200 - 250 - 300

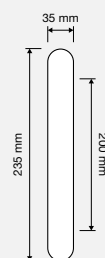
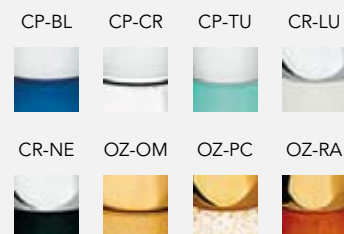



ALDAR | COD. 920 MN 218

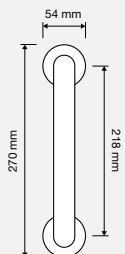
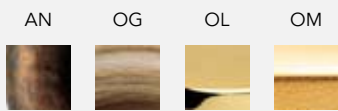

DALIA | COD. 600 MN 218

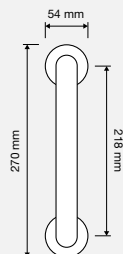
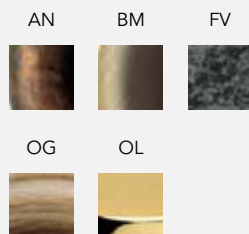

MARGHERITA | COD. 368 MN 240

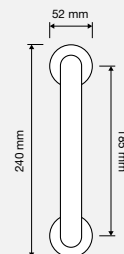
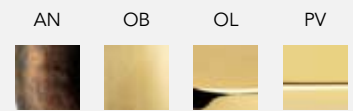

MANIGLIONI / PULL HANDLES



MARINA | COD. 755 MN 320

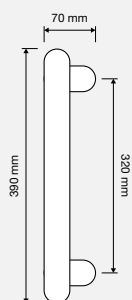
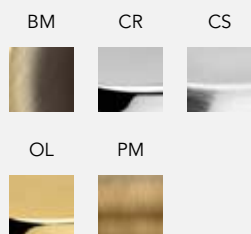

CREATIVE CLASSIC | COD. 1130 MN 380
Interassi disponibili / available distances
380 - 550 - 700

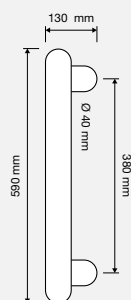
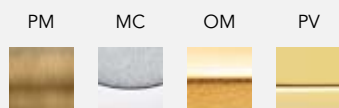

CREATIVE CROWN | COD. 1144 MN 380
Interassi disponibili / available distances
380 - 550 - 700

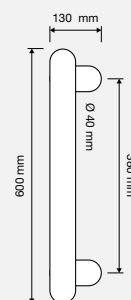
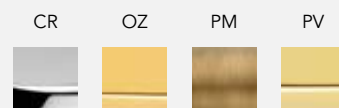



COD. 370 MN 296

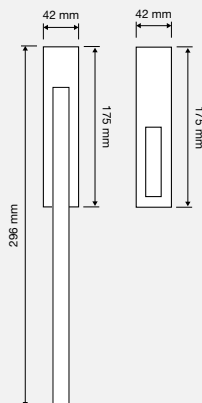

COD. 373 MN 296

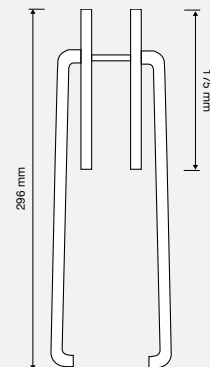

MANIGLIONI / PULL HANDLES



COD. 505 MN 315

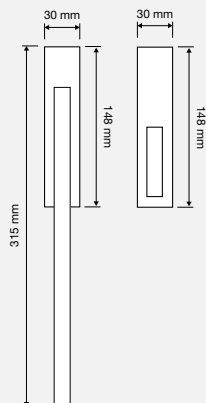

COD. 505 MC 315

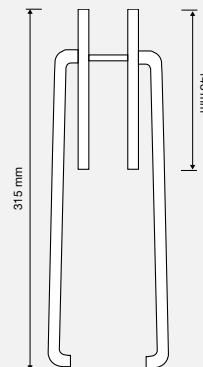



GARDA | COD. 400 PT

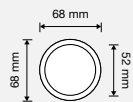
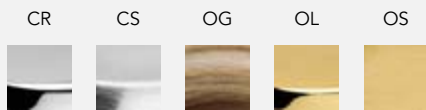

GIOVE | COD. 637 PT 070

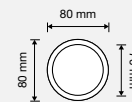
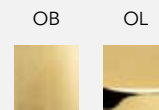

MARGHERITA | COD. 430 PT 070

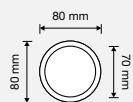
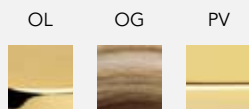

VENERE | COD. 410 PT 070

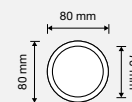
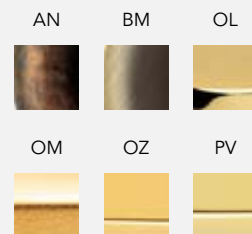

POMOLI PER PORTE / DOOR KNOBS



OPEN | COD. 1105 PT



ELIKA | COD. 990 PT

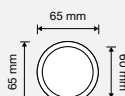

ROSE | COD. 996 PT

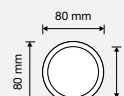

OPEN | COD. 1105 PG 019

CR CS OL OZ



ELIKA | COD. 990 PG 108

BM MC OM



ROSE | COD. 996 PG 108

AN BM FV

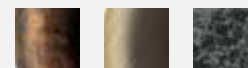

POMOLI PER PORTE / DOOR KNOBS



SABA | COD. 401 PT 070

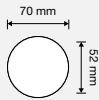

SFERA | COD. 735 PT 070

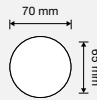

CUORE | COD. 416 PT

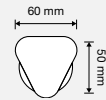

SABA | COD. 441 PG 101

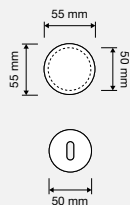
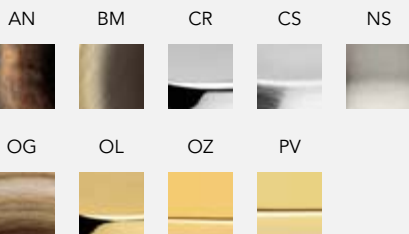

SFERA | COD. 735 PG 101

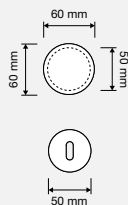
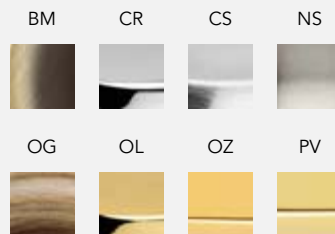

CUORE | COD. 416 PG 101

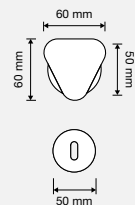
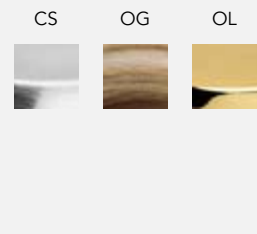

POMOLI PER PORTE / DOOR KNOBS



DELFINO | COD. 955 PT

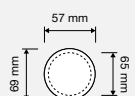

SIRENA | COD. 810 PT

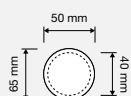

FLAVIA | COD. 685 RO 102



DELFINO | COD. 955 PG 102

BM CS MC OL OM

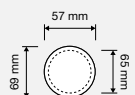

SIRENA | COD. 810 PG 103

AN OL OZ

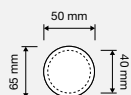

FLAVIA | COD. 685 RB 102

AN BM OG OL

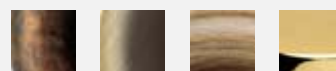



COD. 977 BA MC

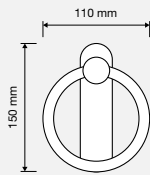

COD. 990 BA OM

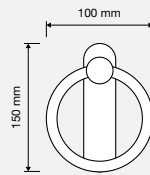

COD. 996 BA BM

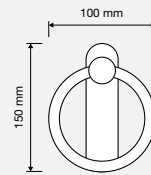

COD. 355 BA OL

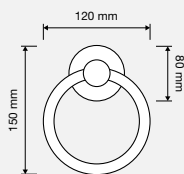

COD. 351 BA OL

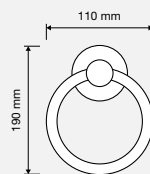

COD. 358 BA OL

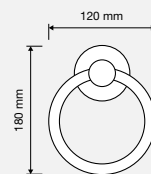

BATTENTI / DOOR KNOCKERS



COD. 359 BA OL

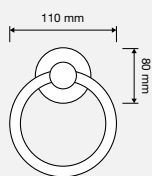

COD. 357 BA OL

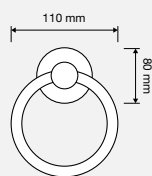

COD. 369 BA OL

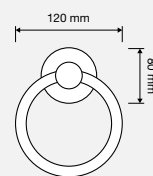

COD. 350 BA OL

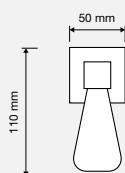



Per venire incontro alle ultime tendenze stilistiche, Linea Cali ha dato letteralmente un taglio alle rosette e bocchette tradizionali valorizzando così il design di ogni maniglia.

To meet the latest trends in design, Linea Cali has literally cut the size of traditional roses and escutcheons thus giving more value to the design of every handle.

Perfetta negli ambienti più moderni, la nuova linea di rosette e bocchette ribassate è disponibile per tutte le maniglie contraddistinte dal relativo logo.

Perfect in the most modern surroundings, the new line of reduced roses and escutcheons is available for all handles that are identified with the relative logo.



ROSETTA RIBASSATA REDUCED ROSE



6 mm

ROSETTA TRADIZIONALE STANDARD ROSE



10 mm

BOCCHETTE / ESCUTCHEONS



COD. 024 BO 0050



COD. 090 BO 0050



COD. 019 BO 0050



COD. 025 BO 0052



COD. 023 BO 0052



COD. 101 BO 0045



COD. 101 BO 0050



COD. 109 BO 0045



COD. 109 BO 0050





COD. 102 BO 0050



COD. 103 BO 0050



COD. 108 BO 0054



COD. 011 BO 0050



COD. 096 BO



COD. 110 BO 0045



BOCCHETTE SET WC / WC ESCUTCHEONS SET



COD. 024 SW



COD. 019 SW



COD. 090 SW



COD. 025 SW



COD. 023 SW



COD. 011 SW



COD. 102 SW



COD. 101 SW 0045



COD. 101 SW 0050



BOCCHETTE SET WC / WC ESCUTCHEONS SET



COD. 103 SW



COD. 108 SW



COD. 109 SW 0045



COD. 109 SW 0050



COD. 009 SW



COD. 010 SW



COD. 018 SW



COD. 078 SW



COD. 091 SW



BOCCHETTE SET WC / WC ESCUTCHEONS SET



COD. 110 SW



COD. 117 NT

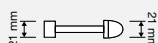

COD. 261 NT

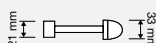

COD. 233 NT

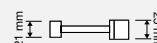

CHIAVI / KEYS



DELFINO | COD. 542 CH

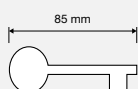

COD. 624 CH

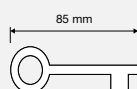

SIRENA | COD. 818 CH

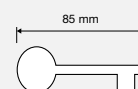



ELLE | COD. 1050 CH

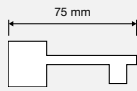

ROSE | COD. 543 CH

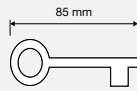

FERMAPORTE / DOORS STOP



COD. 211 FE

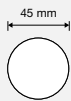

COD. 613 FE



COD. 214 FE

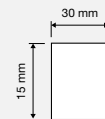

COD. 212 FE

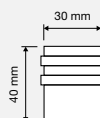

BRERA | COD. 1172 FE

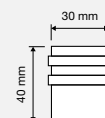

COPRICERNIERE / HINGE COVERS



COD. 247 CI BM (Ø INT. 20 MM)

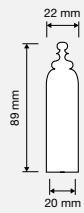

COD. 246 CI CS (Ø INT. 16 MM)

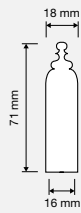

COD. 245 CI OG (Ø INT. 14 MM)

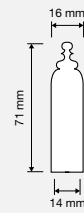

COD. 242 CI NS (Ø INT. 20 MM)

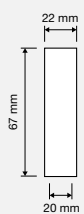

COD. 241 CI OS (Ø INT. 16 MM)

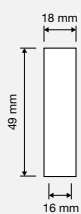

COD. 240 CI OL (Ø INT. 14 MM)

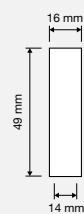

CATENACCI E CAMPANELLI / DEADBOLTS AND BELLS



COD. 305 CA



COD. 316 IV



COD. 317 IV



COD. 318 IO



COD. 139 CP

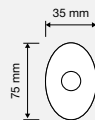

COD. 352 CP

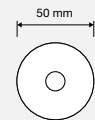

COD. 103 CP



AN



CR



CS



NS



OB



OL

Interassi disponibili / available distances
80 - 100 - 120 - 180 - 200 - 250
300 - 350 - 400 - 450 - 600 MM

CREMONESI MP ASTE ESTERNE

WINDOW HANDLES GRATZ MP FOR EXTERNAL RODS

MODELLI / MODELS



ANELLO | COD. 340 CRMP 3P2F



SABA | COD. 625 CRMP 3P2F



COD. 340 CRMPAE

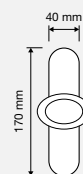

COD. 545 CRMPAE

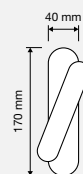

COD. 625 CRMPAE

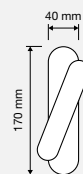



ZEN | COD. 1156 AB

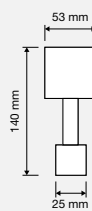

COD. 910 AB

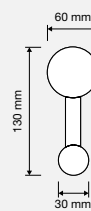

MANIGLIE E ACCESSORI PER PORTE BLINDATE

HANDLES AND ACCESSORIES FOR ARMORED DOORS



GARDA | COD. 252 B1

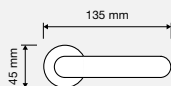

SABA | COD. 251 B1

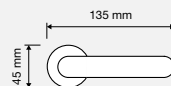

SFERA | COD. 260 B3

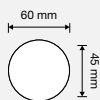

GARDA | COD. 400 PT 065

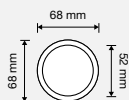

GIOVE | COD. 259 B3

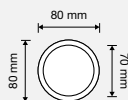

SABA | COD. 401 PT 070

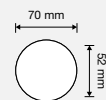

MANIGLIE E ACCESSORI PER PORTE BLINDATE HANDLES AND ACCESSORIES FOR ARMORED DOORS



GARDA | COD. 258 B2

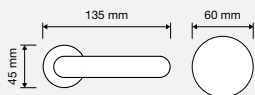

GARDA | COD. 255 B2

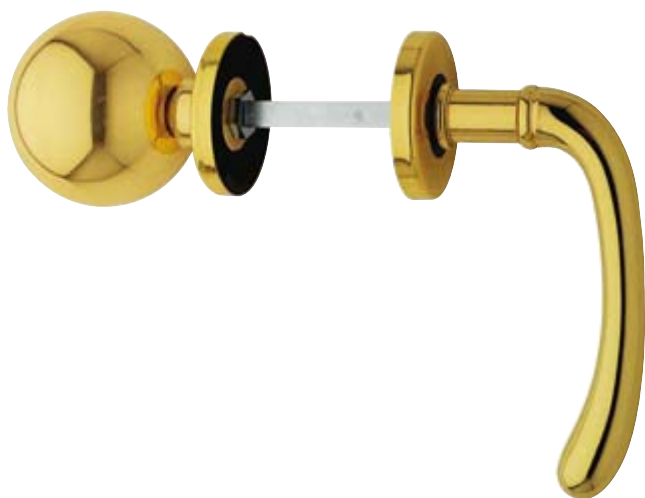
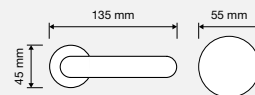

SABA | COD. 257 B2

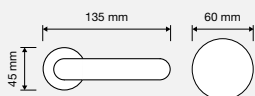

SABA | COD. 254 B2

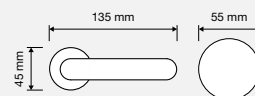

MANIGLIE E ACCESSORI PER PORTE BLINDATE

HANDLES AND ACCESSORIES FOR ARMORED DOORS



COD. 298 B5



COD. 297 B5



COD. 300 B4

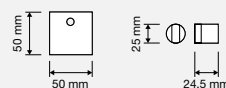

COD. 293 B4



COD. 294 B4



COD. 248 B4



COD. 249 B4



COD. 264 B5



COD. 262 B4



MANIGLIE E ACCESSORI PER PORTE BLINDATE HANDLES AND ACCESSORIES FOR ARMORED DOORS



COD. 261 B4



COD. IT010 60-100 MM



COD. 236 B6

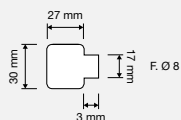

COD. 237 B6

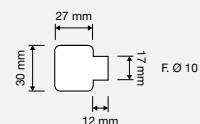

COD. 267 B6

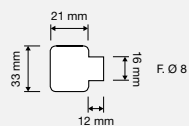

COD. 295 B6

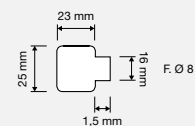

PLACCHE INCASSO / INSET HANDLE KIT

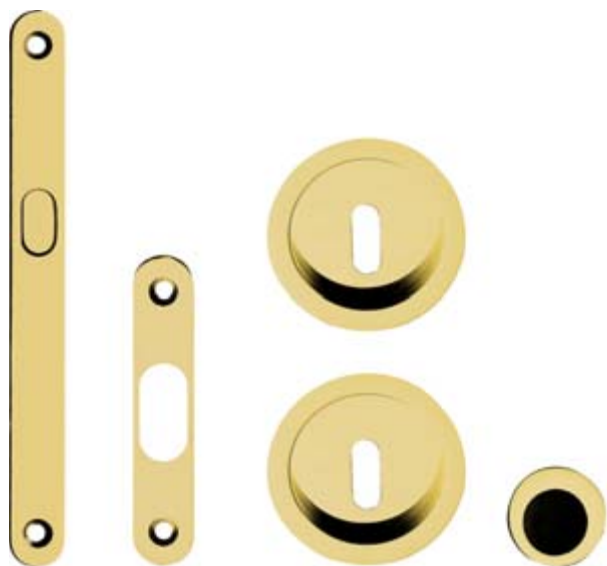

COD. 332 KT

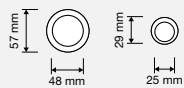

COD. 331 KT



COD. 168 PI



COD. 169 PI



PLACCHE INCASSO / INSET HANDLE KIT

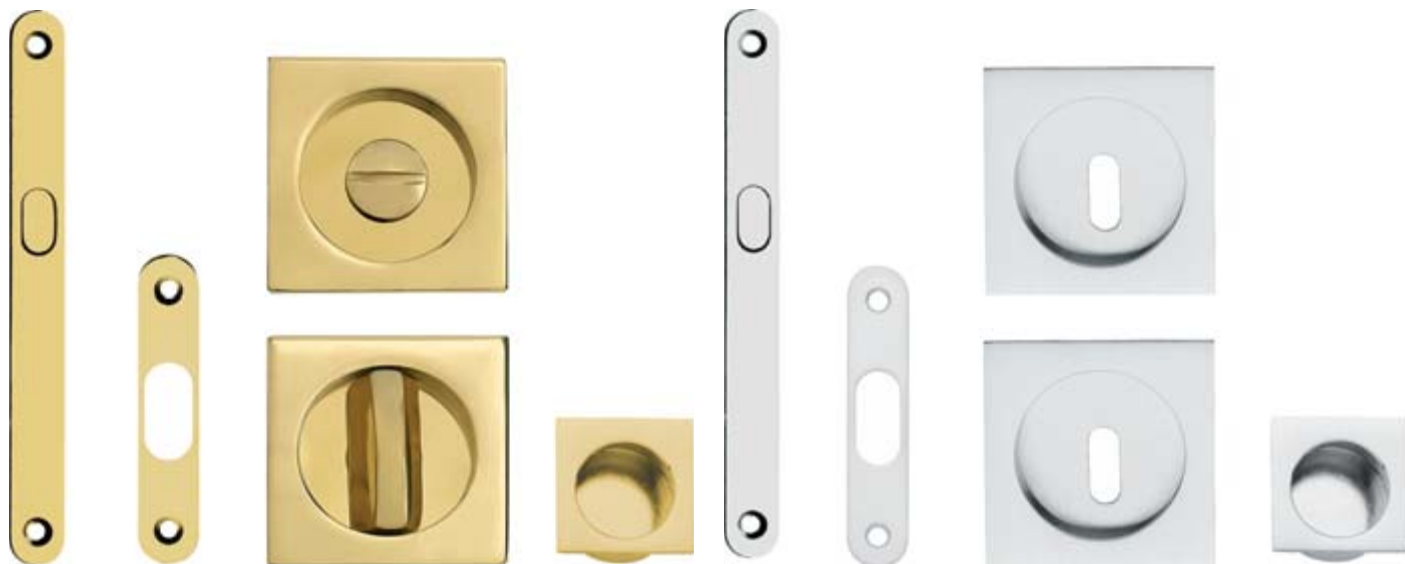

COD. 184 KT

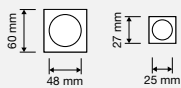

COD. 186 KT

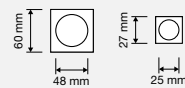

COD. 190 PI



COD. 189 PI



PLACCHE INCASSO / INSET HANDLE KIT



COD. 629 PI

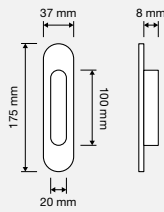

COD. 819 PI

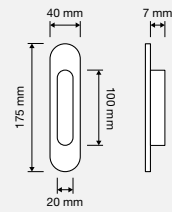

COD. 179 PI

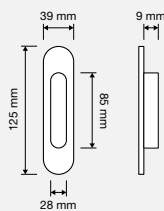

COD. 849 PI

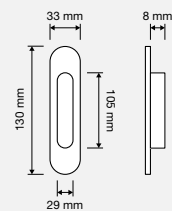

PLACCHE INCASSO / INSET HANDLE KIT



BRERA | COD. 1173 PI

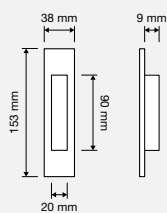

PROFILO | COD. 1042 PI

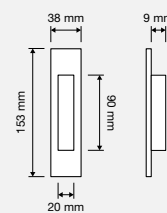

POMOLI PER MOBILI / CABINET KNOBS



ROSE | COD. 996 PB 0030 AN

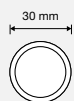

ROSE | COD. 996 PB 0030 BM

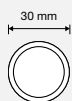

ROSE | COD. 996 PB 0030 FV



ROSE | COD. 996 PB 0030 OF



ROSE | COD. 996 PB 0030 OZ



SIRENA | COD. 202 PB 0027 AN



SIRENA | COD. 202 PB 0032 AN

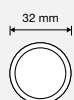

POMOLI PER MOBILI / CABINET KNOBS



DAISY | COD. 1070 PB 0030 BM

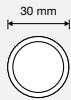

DAISY | COD. 1070 PB 0030 FV



DAISY | COD. 1070 PB 0030 OB



DAISY | COD. 1070 PB 0030 OF



DAISY | COD. 1070 PB 0030 OZ



DAISY | COD. 1070 PB 0030 PM





ESPOSITORE DA PAVIMENTO (12 COLLEZIONI)
FLOOR DISPLAY (12 COLLECTIONS)
COD. 065 AC

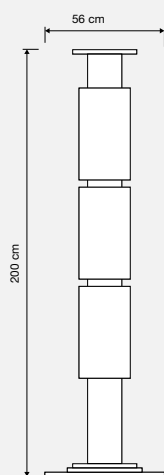

ESPOSITORE DA PARETE (6 COLLEZIONI)
WALL DISPLAY (6 COLLECTIONS)
COD. 066 AC

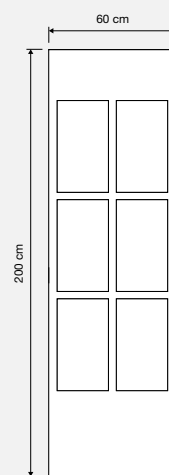



ESPOSITORE DA PAVIMENTO BIFACCIALE
FLOOR DISPLAY
COD. 061 AC

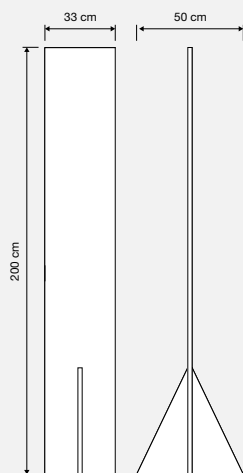

ESPOSITORE DA PARETE
WALL DISPLAY
COD. 064 AC

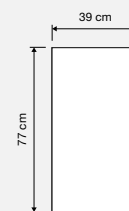



VETROFANIA BIFACCIALE
WINDOW DECALS
FISH CRYSTAL | COD. VET 001

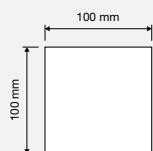

VETROFANIA BIFACCIALE
WINDOW DECALS
LIBERTY | COD. VET 002

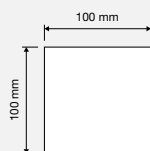

VETROFANIA BIFACCIALE
WINDOW DECALS
MARINA | COD. VET 003

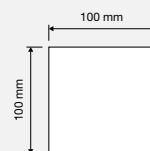

VETROFANIA BIFACCIALE
WINDOW DECALS
ROMBO | COD. VET 004

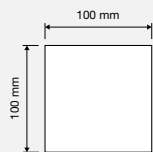

VETROFANIA BIFACCIALE
WINDOW DECALS
SHELL MESH | COD. VET 005

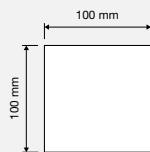

VETROFANIA BIFACCIALE
WINDOW DECALS
SISSI | COD. VET 006

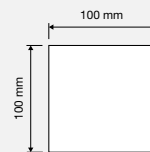



ADESIVO TRASPARENTE / TRANSPARENT STICKER COD. ADR 500

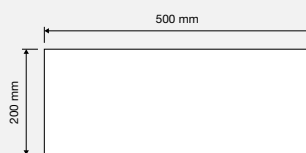

ADESIVO TRASPARENTE / TRANSPARENT STICKER COD. ADR 300

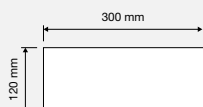

ADESIVO / STICKER COD. ADT 060



ISTRUZIONI DI MONTAGGIO / MOUNTING INSTRUCTIONS

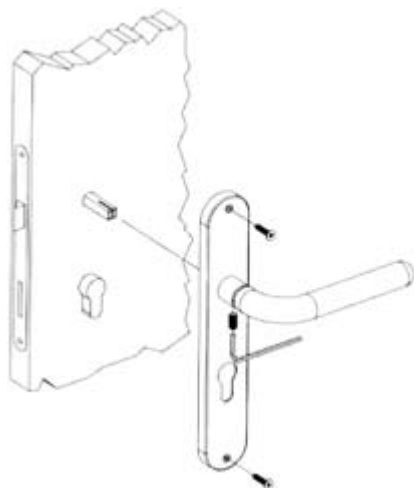

Sistema di montaggio per maniglia con placca.
Fixing system for door handle on plate.

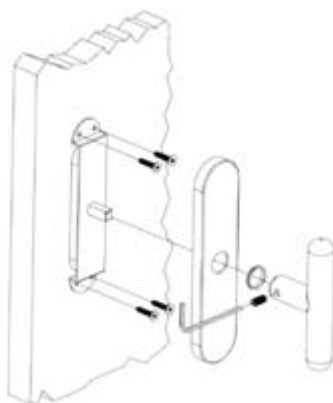

Sistema di montaggio maniglia per finestra.
Fixing system for window handle.

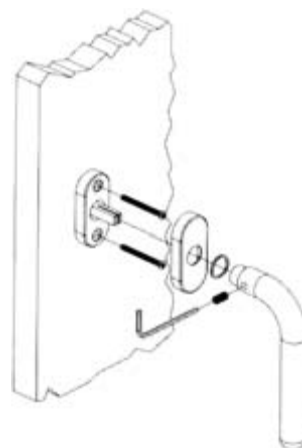

Sistema di montaggio maniglia per finestra con movimento 4 scatti.
Fixing system for window pull, 4 clicks positions.

Fixing system for window pull, 4 clicks positions.

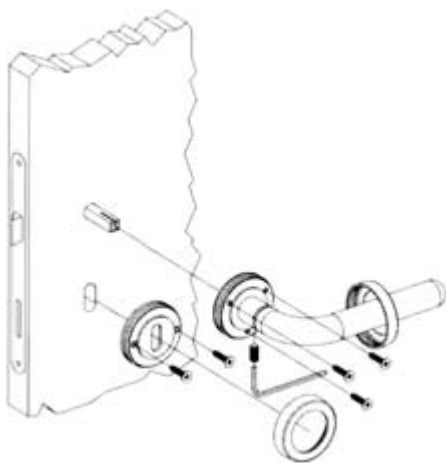

Sistema di montaggio per maniglia con rosetta.
Fixing system for door handle on rose.

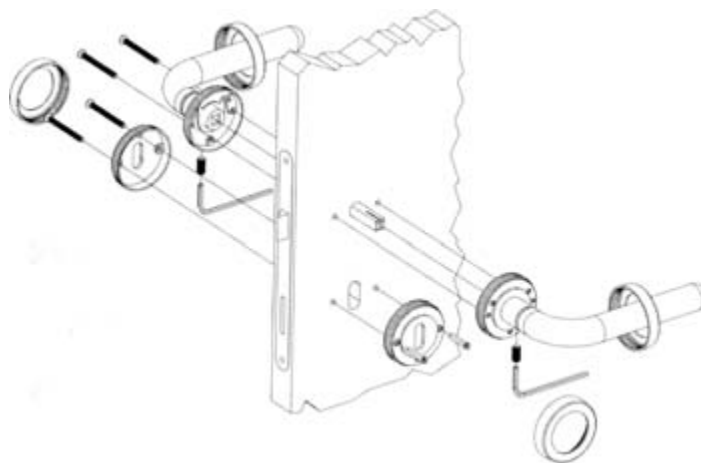

Sistema di montaggio con viti passanti (M3) per maniglia con rosetta.
Through assembly (M3 screws) for door handles on rose.

ISTRUZIONI DI MONTAGGIO / MOUNTING INSTRUCTIONS

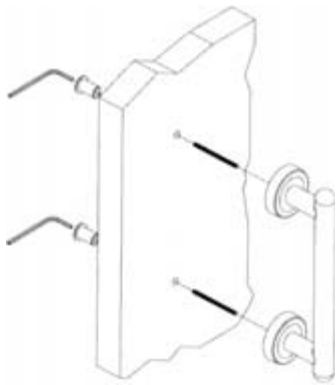

Sistema di fissaggio singolo maniglione su porta in legno (maniglioni con rosette art.102-103-113).

Fixing system for a single pull handle on a wooden door (pull handles with rose art.102-103-113).

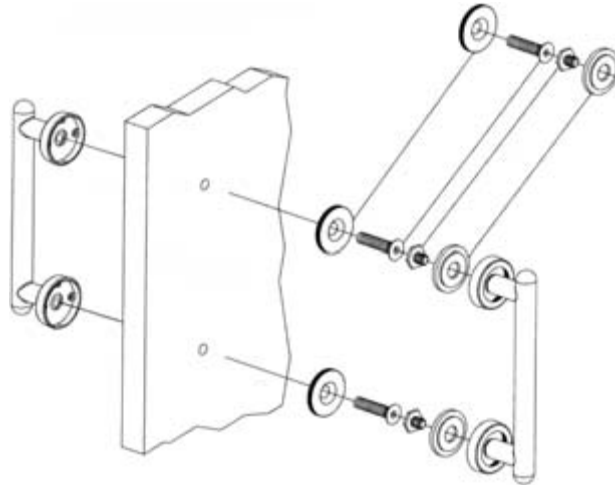

Sistema di fissaggio di una coppia di maniglioni su porta legno (maniglioni con rosette art.102-103). Accessori da ordinare separatamente (rif. listino prezzi art.118MN).

System for fixing a pair of pull handles on a wooden door (pull handles on rose art.102-103). Fixing accessories to order separately (ref. price list art.118MN).

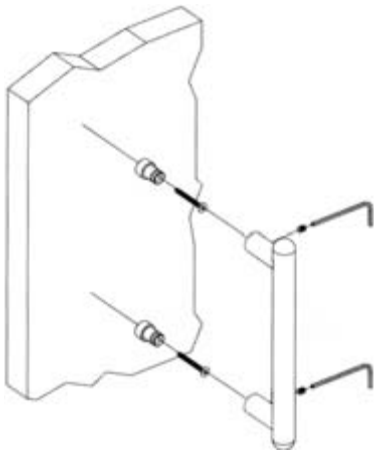

Sistema di fissaggio singolo maniglione su porta in legno.

Fixing system for a single pull handle on a wooden door.

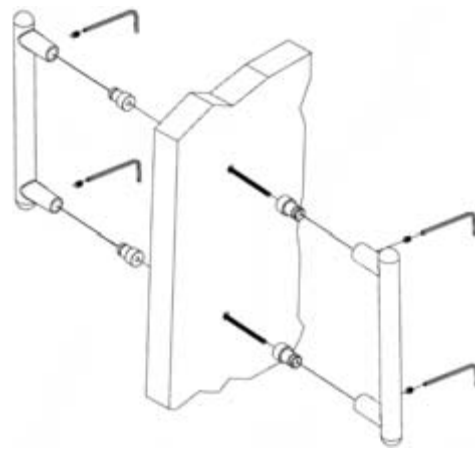

Sistema di fissaggio di una coppia di maniglioni su porta legno.

System for fixing a pair of pull handles on a wooden door.

ISTRUZIONI DI MONTAGGIO / MOUNTING INSTRUCTIONS

Posizionamento e fissaggio con dima per maniglie con rosetta e bocchetta 019.

Fixing system for sets of rose and escutcheon 019 by locating jig.

CLICK-CLACK! YALE

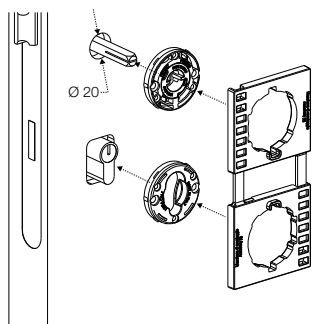

STEP 1/3

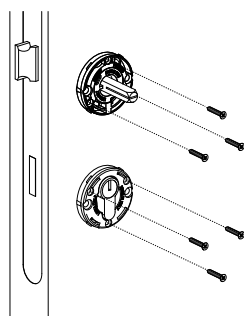

STEP 2/3

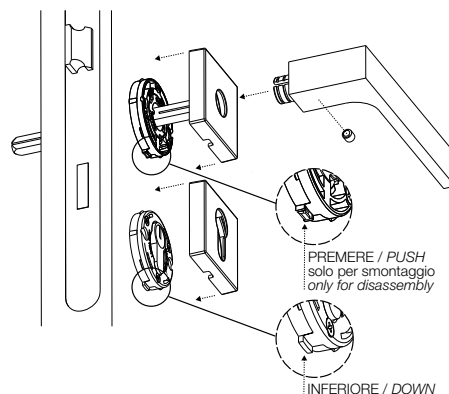

STEP 3/3

CLICK-CLACK! PATENT KEY

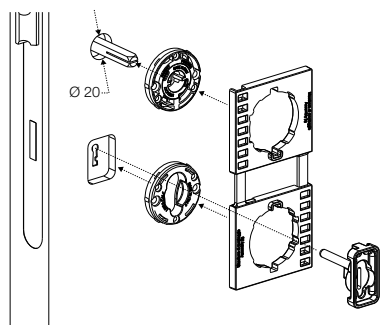

STEP 1/3

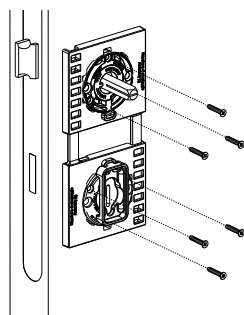

STEP 2/3

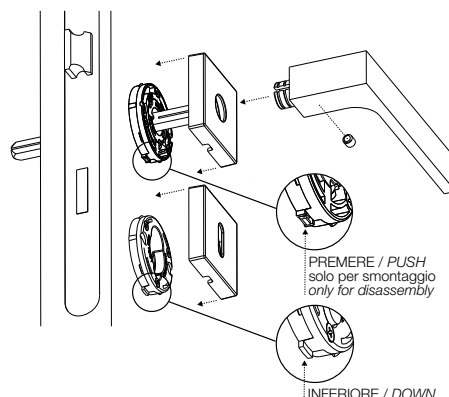

STEP 3/3

CLICK-CLACK! TOILET

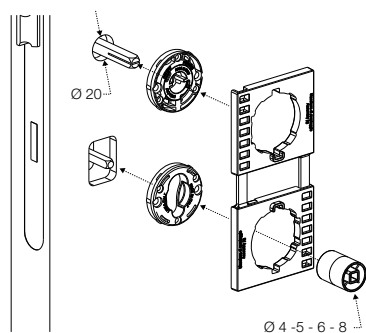

STEP 1/3

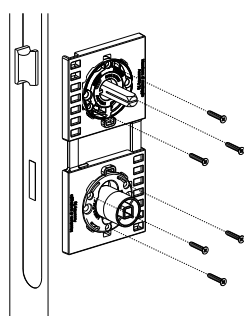

STEP 2/3

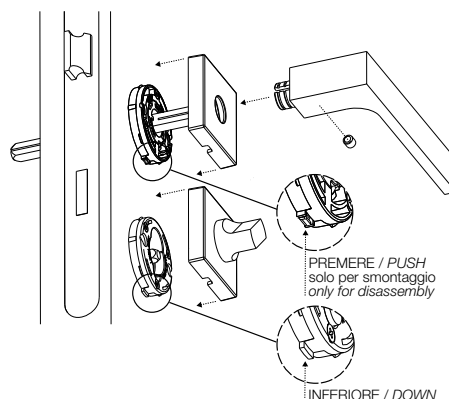

STEP 3/3

ISTRUZIONI DI MONTAGGIO / MOUNTING INSTRUCTIONS

Dima per esecuzione fori passanti interasse 38mm.
Drilling jig for bolt through holes 38mm distance.

CLICK-CLACK! YALE

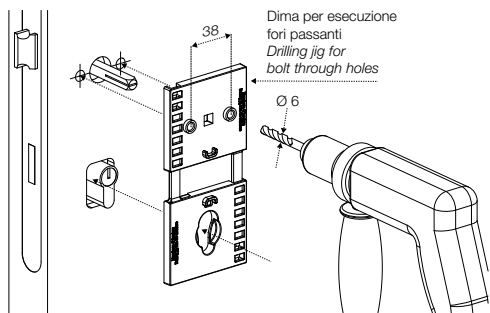

STEP 1/3

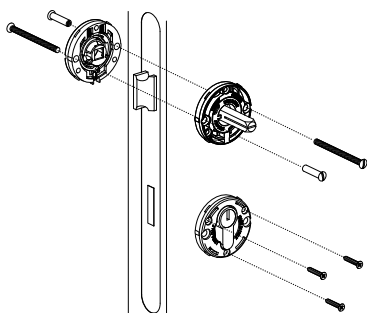

STEP 2/3

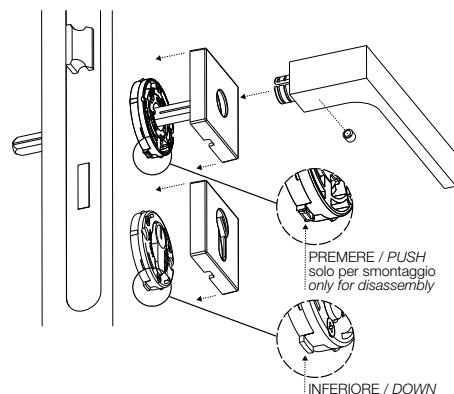

STEP 3/3

CLICK-CLACK! PATENT KEY

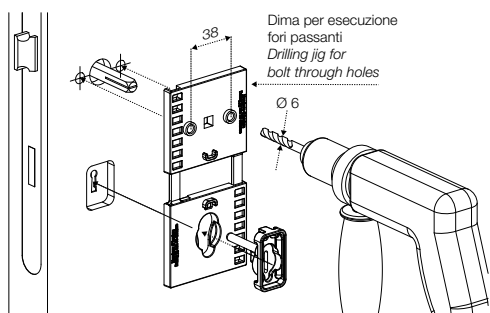

STEP 1/3

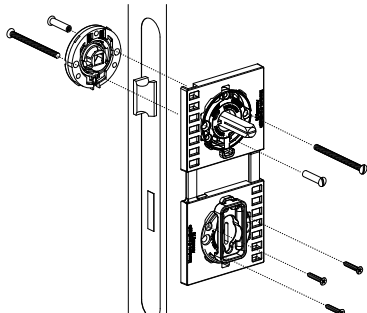

STEP 2/3

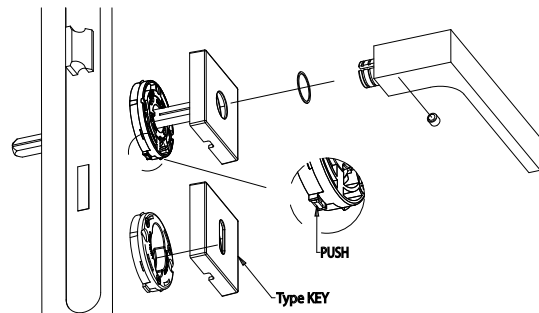

STEP 3/3

CLICK-CLACK! TOILET

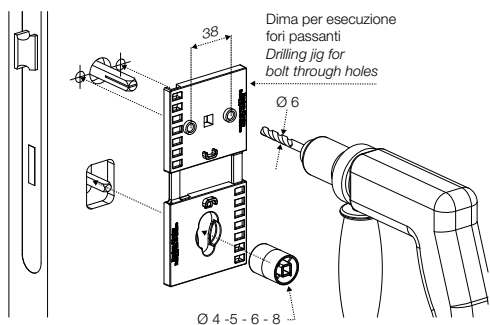

STEP 1/3

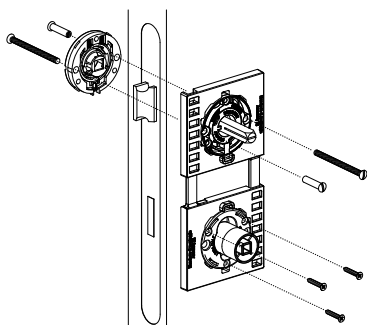

STEP 2/3

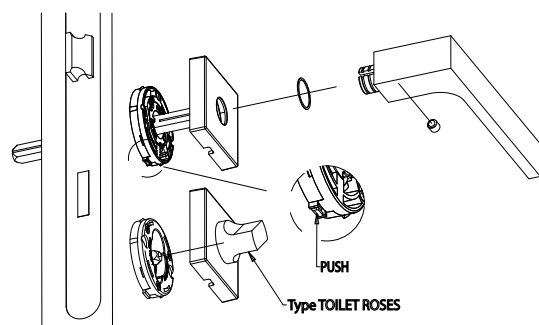

STEP 3/3

Linea Cali® è un marchio registrato.

Linea Cali® is registered trademark.



LINEA CALÌ SRL
DI CALÌ DANILO, CALÌ PAOLO
E FACCHETTI MARIO

VIA COMUNALE, 89/91
25079 VOBARNO (BS) - ITALY

TEL. +390365599198
FAX +390365599971

EMAIL INFO@LINEACALI.IT
WEB WWW.LINEACALI.IT

